

END CASTING.

FILE OUT CORNER BACK OF POLING POCKET TO FIT SIDE.

DRILL HOLES IN CASTING TO FASTEN ALL PARTS WITH BRADS DRIVEN THROUGH HOLES INTO WOOD BENEATH.

#22 WIRE

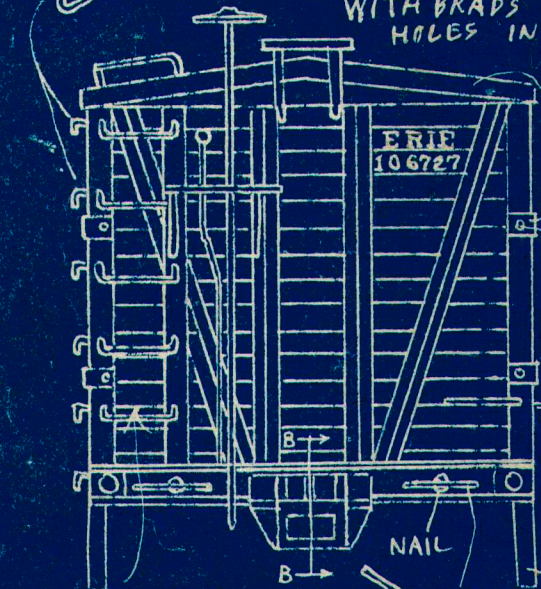

ERIE 106727

BRISTLE-BOARD 1/2" BANK PINS

SERIES NUMBERS 103700 TO 107499

NAIL RUNG #22 WIRE

FASTEN LADDER HERE INSTEAD OF GRAB IRONS

TIN-CAN METAL CUT & BENT TO SHAPE

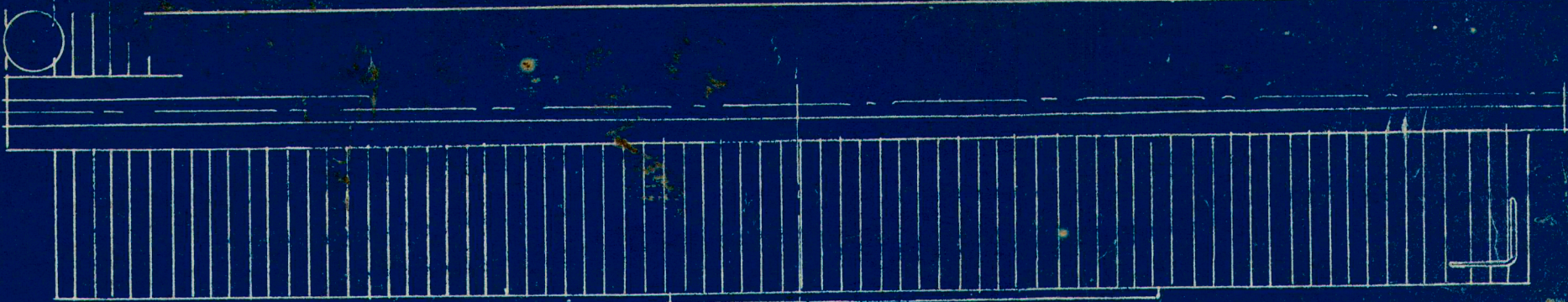

BRISTLE-BOARD PIECES 1/2" BANK PINS

WHITE BLACK



#22 WIRE

EW 9-9
EH 12-6
IL 36-5
IH 8-0
IUF 24-43

ERIE 106727

CAPY. 80000
LD. LMT. 95000
LT. WT. 47500

ANDREWS TRUCKS

1 5/16"

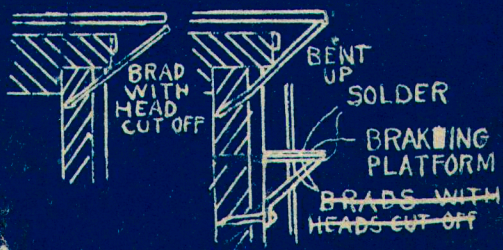

BRAD WITH HEAD CUT OFF

BENT UP SOLDER

BRAKING PLATFORM

BRADS WITH HEADS CUT OFF

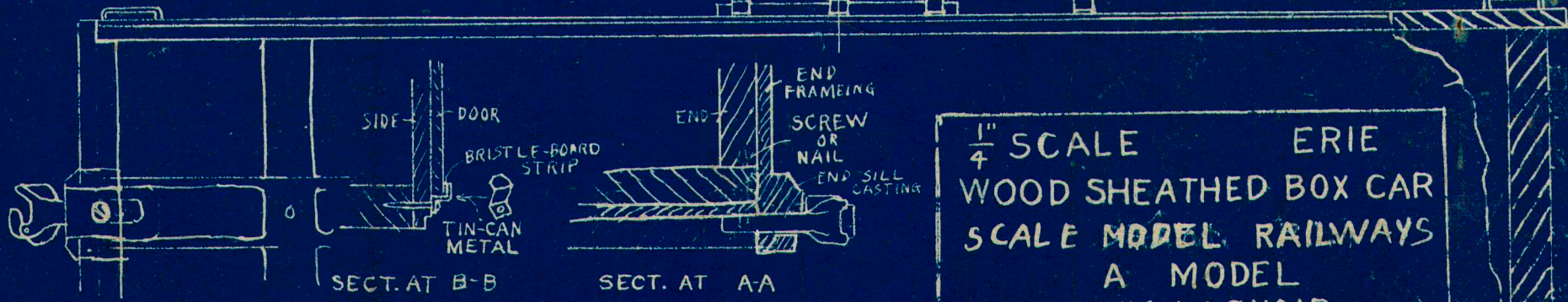

SIDE DOOR

BRISTLE-BOARD STRIP

TIN-CAN METAL

SECT. AT B-B

END FRAMING

SCREW OR NAIL

END SILL CASTING

SECT. AT A-A

1/4" SCALE ERIE WOOD SHEATHED BOX CAR SCALE MODEL RAILWAYS A MODEL BY WM. J. LENOIR

S M R

TEMPERARY DRAWING.