

Roundhouse Products

Model Railroad
H-O GAUGE CATALOG

1973



Featuring a Complete Line of Scale

New **1850**

OLD TIMER SERIES
buildings

\$1⁰⁰

ROUNDHOUSE H'O GAUGE SCALE MODEL

WHY MODEL RAILROADING?

First, it is a source of pleasure from the first kit you assemble on through the many paths you may take in building and operating a layout—large or small, simple or complicated. Beyond that, it can be enjoyed alone, with others who share your interest, as a bridge between adult and child—any, or all of these. You may even develop a secondary hobby as a result of your interest in Model Railroading. The scope of this hobby includes photography, engineering, electronics, painting, carpentry and many other such fields. You may wish to join a local club among whose members may be airplane pilots or accountants, business men or lawyers, doctors or railroad engineers, plumbers or mechanics—these men are alike in their enthusiasm for the hobby.

Model Railroading is an expanding, active hobby with such a variety of products and facets that you need never outgrow it. We at Roundhouse have been making model railroad kits for over 25 years, and from the beginning, have established **PRECISION IN REPRODUCTION** as our standard from the first engineering drawing through many months of cutting fine detail into steel molds, so that the final production yields a model which we are proud to have carry our name.

MODEL DIE CASTING, INC.

P.O. BOX 926 HAWTHORNE, CALIF. 90250

All prices are subject to revision and change without notice.



RAILROAD EQUIPMENT

CONTENTS:

INTRODUCTION	2,3	Caboose (2- and 4-window) Style	15
OLD TIMER H-C BUILDING SECTION	4	50' AAR Box Cars	16
H-C Buildings Line	5	Plug Door Box Cars	17
MOTIVE POWER SECTION		Ore Cars	18
Diesel	6	Gondola & Flat Cars	19
Steam Locomotive	7	Covered Hoppers	20
ROUNDHOUSE H-C SCALE MODERN AND "OLD TIMER" SERIES SECTION	8	ACCESSORIES SECTION	21
OLD TIMER SERIES		Diesel Parts	22
36' Billboard	9	Locomotive Parts	23, 24, 25
36' Box Car & Refrigerator	10	PASSENGER CAR SECTION	26
36' Stock Car & 26' Tank Car	11	86' Pullman Palace Cars	26
34' Caboose	12, 13	50' Pullman Palace Cars	27
MODERN SERIES SECTION		50' Circus Cars	28
40' AAR Box Car	14	50' Harriman Cars	29
40' Box Car (Truss Side-Horizontal Rib)	15	34' Overton Palace Cars	30
		50' Express Refrigerator Cars	31
		NEW RELEASES	32



New for '73, Roundhouse Products proudly presents
our H-O Scale "Old Timer" building line.

- Injected molded plastic / for years of lasting beauty.
- Modular construction / ease of freelance designing.
 - Super extra individual detailing parts / no two buildings alike.
 - Space saving size / will fit any layout (large or small).

ANNOUNCING ROUNDHOUSE

GOLD RUSH 18



GOLD!! — The West . . . or the '49's — This was the Mother Lode country. The Mother Lode lies on both sides of "California Highway 49", winding along the western United States' slope of the Sierra Mountains in California.

When gold was found at Sutters Creek in 1848 by James Marshall, a sleepy country awoke! Buildings sprang up, saloon keepers appeared, and dance halls and bawdy houses rose up practically overnight. At first, they were nothing more than rough planks and canvas but, with time, "brick and iron door" buildings became the rule. Unlike any buildings ever designed, the "iron door" types were a must because of the constant danger of fire which threatened all early communities of the west. Some historians have gone so far as to explain these fascinating structures by saying the iron doors were used to keep out those unwanted lead slugs which were in abundance in those days.

Today, of the approximately five hundred mining towns described by historians, most have completely disappeared from sight; only an occasional foundation may be sighted among the tall pines. But it is here that Roundhouse has come to recreate, for you, the real history of this era with a line of truly authentic buildings.

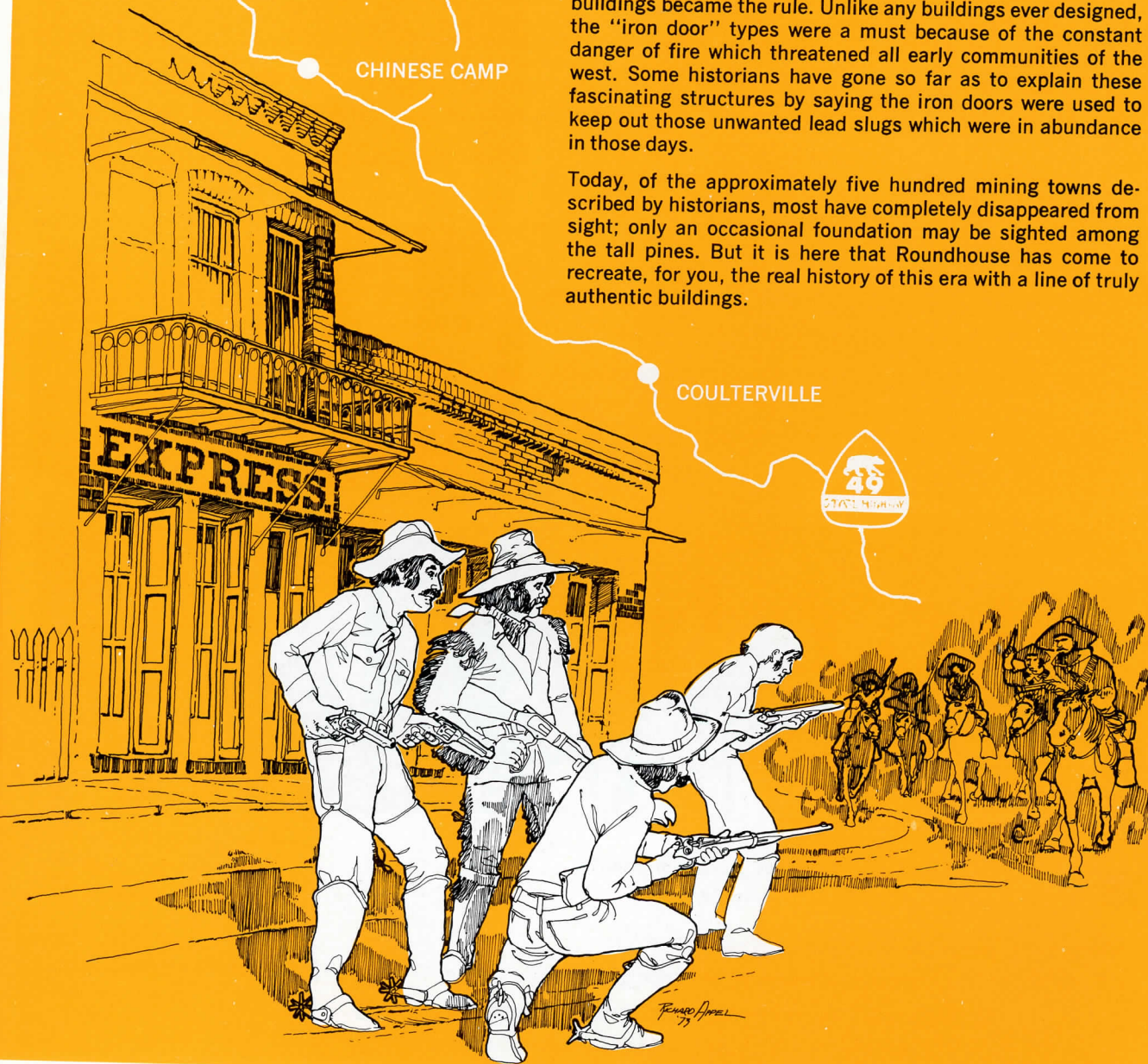

50

H-O SCALE MODEL OLD TIMER BUILDING SERIES

The West comes alive again through the scale model buildings of Roundhouse Products' "Old Timer" Series. Each model building in our new series is detailed directly from buildings discovered in the California Mother Lode gold country. No expense has been spared in bringing to you, the discriminating modeler, buildings correct in every minute detail. Each kit is produced from precision engraved dies, hand executed, down to the finest scale bricks and authentic working iron door shutters.

Each building in this series was designed on what we call "modular construction". With this series you can recreate any and all of those fascinating Gold Rush era buildings. Each kit contains an individually designed structure. By purchasing our different styles, you can combine them and, either by substitution of ends or sides, give your buildings your own character and charm. As an example, Roundhouse is producing two of the most sought after styles — stone wall and brick wall buildings. All you need is one of each to complete a mixed style; or combine the two, one on top of the other, for a two-story building. As you can see, we truly have gone one step further with our buildings. Just look over the items in our catalog and imagine what you can do without all that cutting and filing you used to have to do.

Roundhouse has taken the work out and put in the real fun!!

*NOTE! Pictures of "OLD TIMER" Buildings were from die samples; closely approximating details in our final kits. Release date early Spring.

1 Story.....\$2.98



#1-01 1 STORY BRICK

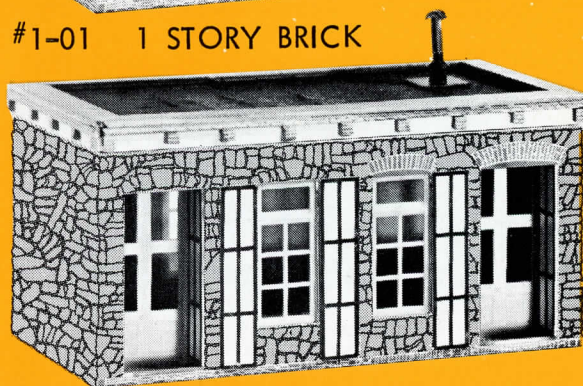

#1-02 1 STORY STONE

2 Story.....\$4.98

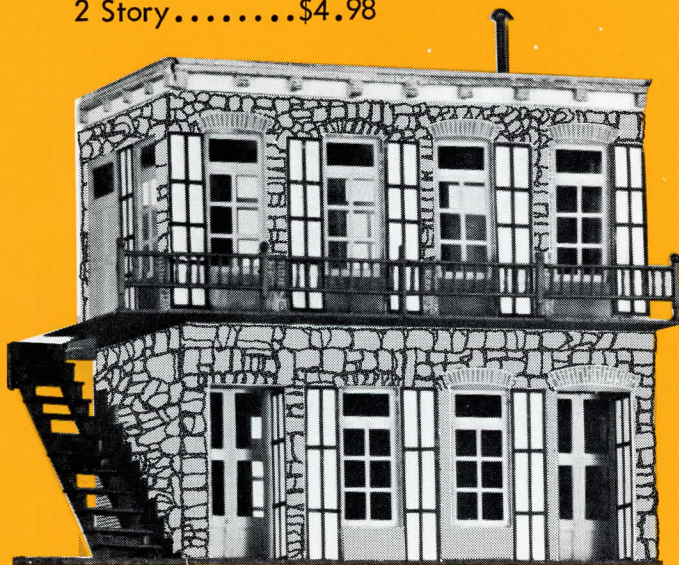

#2-02 2 STORY STONE



#2-01 2 STORY BRICK

5

ROUNDHOUSE
Products



Ready-to-Run

Diesel

This Diesel is the original, first 60 ton, 300 horse power box-cab, as collaborated and built by American Locomotive Works, General Electric, and Ingersoll-Rand Co. This is a sturdy built model designed for years of trouble free operation, long lasting looks. The one piece body is molded of high-impact styrene, pre-painted and authentically lettered in 12 roadnames. Model is complete with couplers & separate attaching super detailing castings. Model is powered by a powerful 5 pole permanent magnet in-line motor (The same power as used on the most expensive imported locomotives.) All four axles are powered, giving this little giant rear pulling power! Designed for any type of track, home or club.

- Roundhouse diesel operates with ALL other H-O equipment.
- Roundhouse diesel requires no special tools.
- Roundhouse diesel comes complete, nothing else to purchase.



Plus

- Easy snap-on super detailing parts.
- Powerful 5 pole in-line motor.
- Ready-to-run diesel is fully guaranteed.

now
\$ 17.98
ea.

ROAD NAMES AVAILABLE

8L-01 Undecorated	8L-6 Reading
8L-02 Striped no name	8L-7 Erie
8L-1 Jersey Central	8L-8 Union Pacific
8L-2 Balt. & Ohio	8L-9 So. Pacific
8L-3 Lehigh Valley	8L-10 Santa Fe
8L-4 U.S. Steel	8L-11 Pennsylvania
8L-5 Ford Motor Co.	8L-12 Ingersoll-Rand

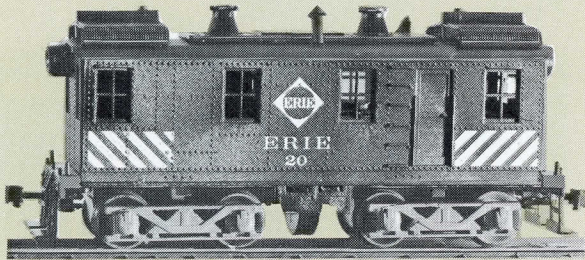

8L-7 Erie

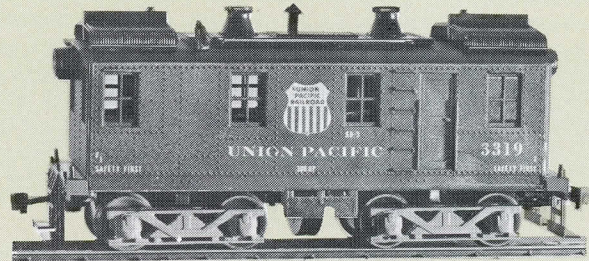

8L-8 Union Pacific



8L-9 So. Pacific

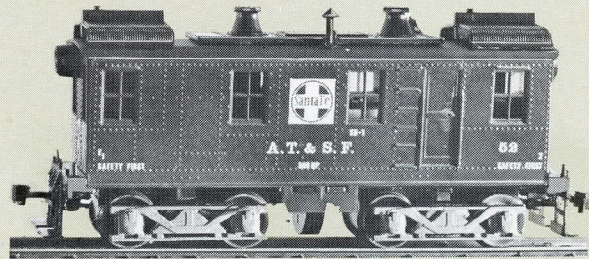

8L-10 Santa Fe



8L-11 Pennsylvania



8L-12 Ingersoll-Rand

LOCOMOTIVES

DIE CAST ALL METAL

- Engineered to last
- Smooth trouble free operation
- Precision scaling and authentic detailing

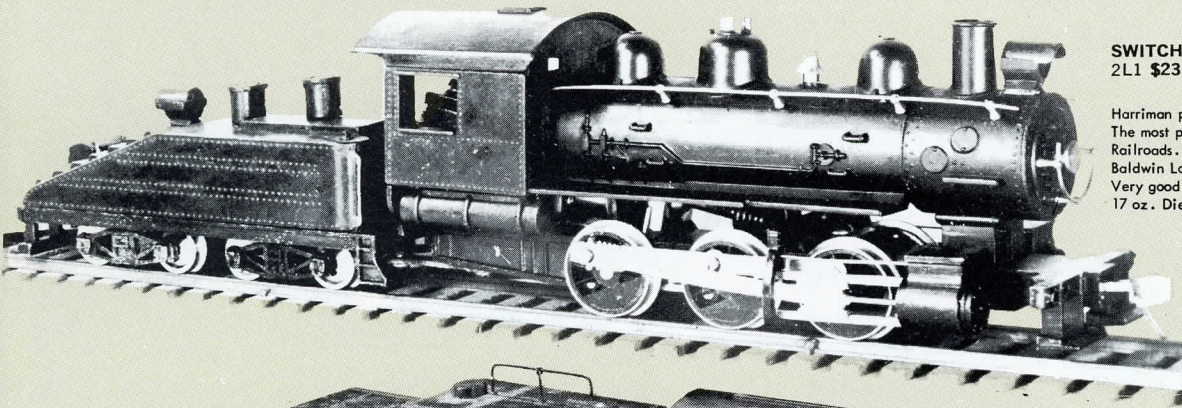

SWITCHER 0-6-0
2L1 \$23.50 Kit

Harriman prototype with slope back tender. The most popular type switcher used by the Railroads. So. Pac. class 1100. Built by Baldwin Loco Works from 1906 to 1911. Very good detail. Total length 8". Wt. 17 oz. Die cast metal. Power Pitt. DC 60.

PRAIRIE 2-6-2
6L1 \$32.50 Kit

AT&SF prototype. Used to pull Death Valley Scotty's "Coyote Special" Good model.

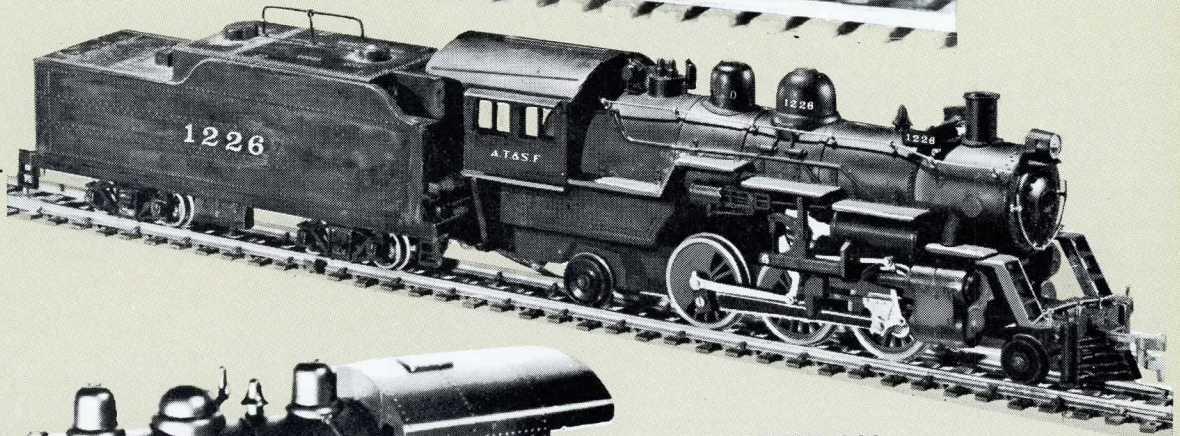

SADDLE TANKER 0-6-0
5L1 \$19.50 Kit

Popular in yard switching, logging, mining and private industry. Made by Baldwin.

ATLANTIC 4-4-2
4L1 \$29.95 Kit

Santa Fe class 1483 to 1498. Built by Baldwin Locomotive works 1910. Follows prototype accurately. Very authentic, with lots of separate detail parts. Runs smooth and powered with a Pittman DC-62B motor.

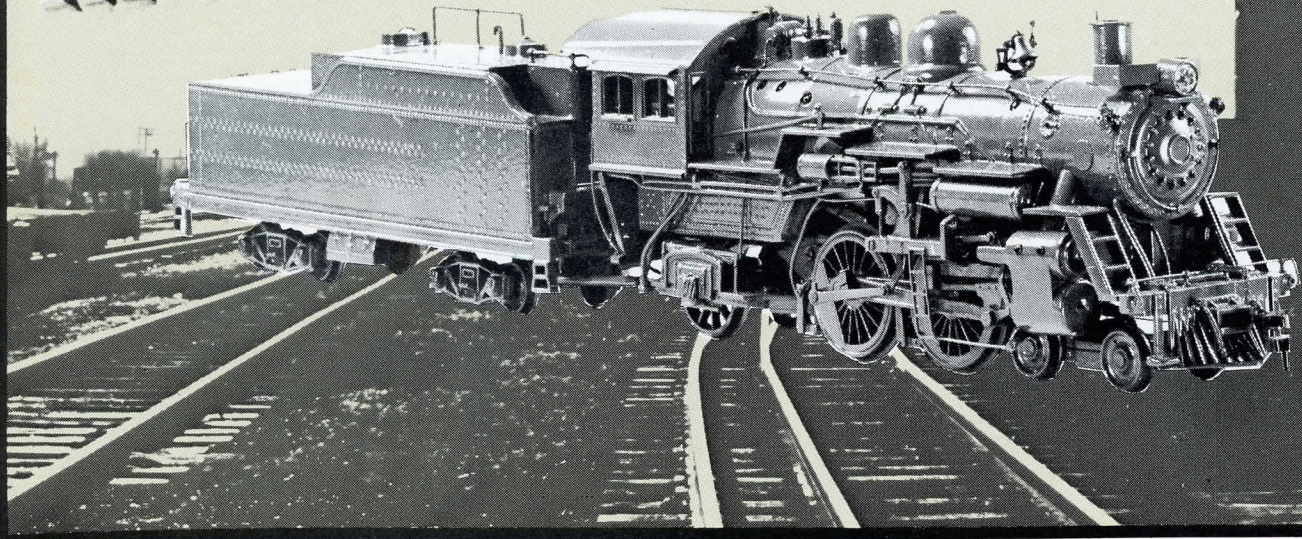
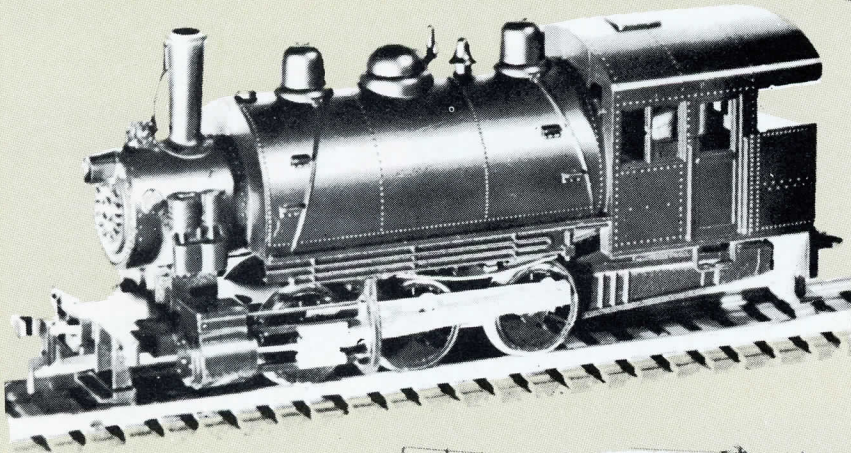

ROUNDHOUSE HO MODERN & OLD TIMER EQUIPMENT



OLD TIMER BILLBOARD REFRIGERATOR CARS

\$3.50 ea.

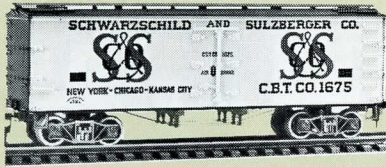

3121 Schwarzschild & Sulzberger

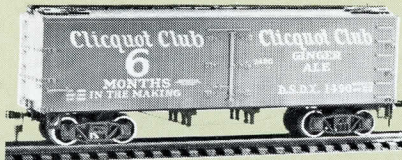

3122 Cliquot Club



3123 Pabst

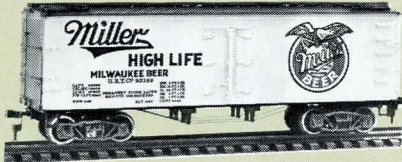

3124 Miller High Life

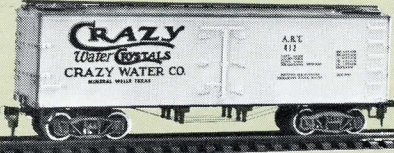

3125 Crazy Water Crystals



3126 Robert's Meats



3128 Elwood's Root Beer

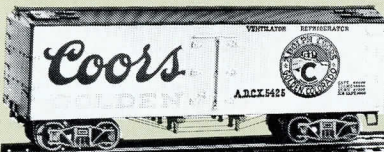

3129 Coor's

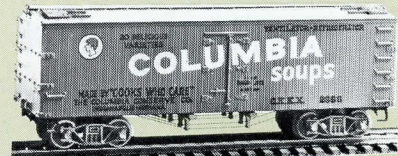

3130 Columbia Soups



3131 Blats Old Heidelberg



3132 Oppenheimer Casing Co.

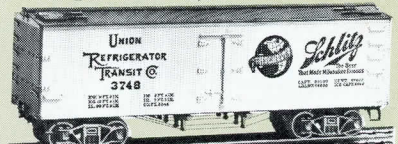

3127 Schlitz



3133 Goetz Country Club Beer

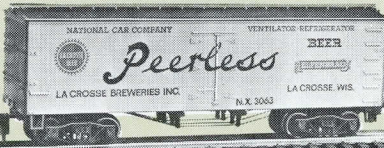

3134 Peerless Beer Company

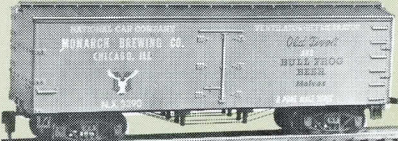

3135 Bull Frog Beer

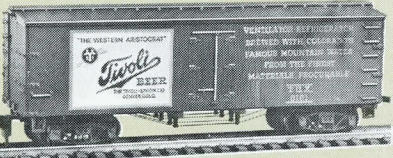

3136 Tivoli Beer



3137 Budweiser Beer

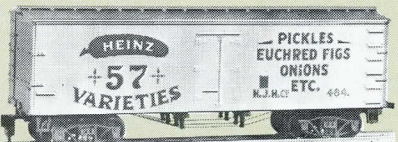

3138 Heinz 57 Varieties

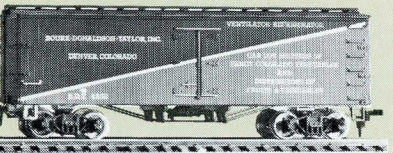

3139 BDT Potatoes

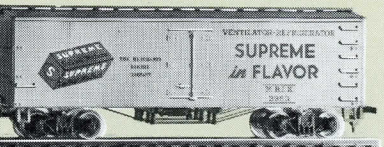

3140 Merchant Biscuits

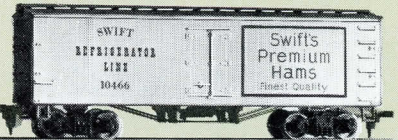

3141 Swift Premium Ham

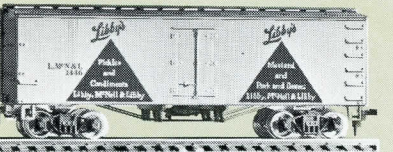

3142 Libby's Pickles

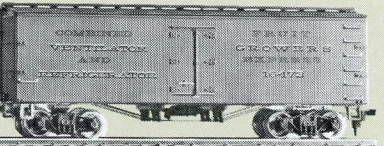

3143 Fruit Growers Express

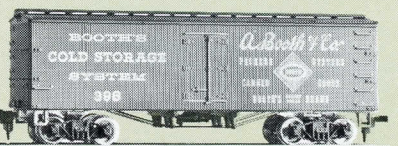

3144 A. Booth & Co.

OLD TIMER

REFRIGERATOR & BOX CARS



Roundhouse brings you something REALLY NEW, with these plastic one-piece body/cast underframe beauties.

36 FOOT REFRIGERATOR CAR

R-36 Unlettered
Yellow & Black

36 FOOT WOOD SHEATH BOX CAR

B-36 Unlettered
Tuscan Red

\$300 ea.

ROUNDHOUSE ★ NEW ★ HO scale 36 FOOT ALL WOOD STYLE "OLD TIMERS"

NEW

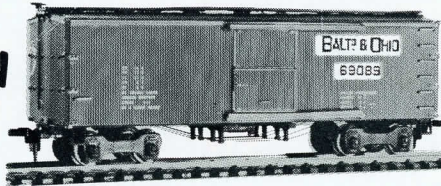

B-367 Baltimore & Ohio Tuscan Red
B-368 NYC & Hudson River Grey

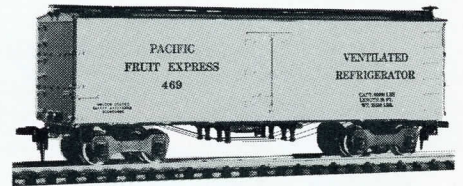

R-362 Pacific Fruit Express Orange & Black
R-365 Chi. Milw. & St. Paul Green & Black

36' REFRIGERATOR CARS

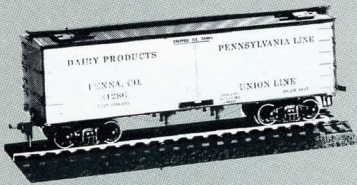

R-361 PENNSYLVANIA
Yellow Body with Black Roof & Ends

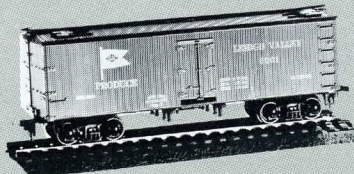

R-369 LEHIGH VALLEY
Green Body with Black Roof & Ends

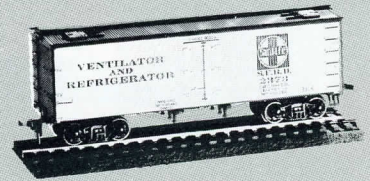

R-363 SANTA FE
Orange Body with Black Roof & Ends

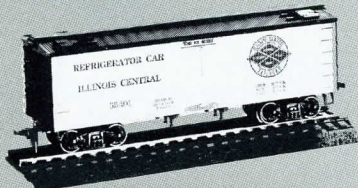

R-366 ILLINOIS CENTRAL
Yellow Body with Black Roof & Ends

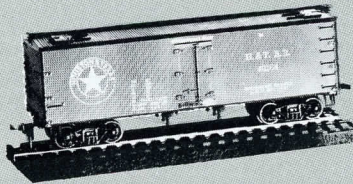

R-368 HOUSTON & TEXAS
Green Body with Black Roof & Ends

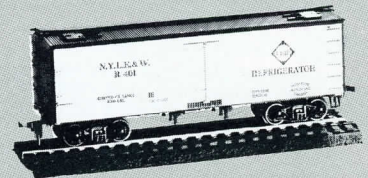

R-367 ERIE
Yellow Body with Black Roof & Ends

36' BOX CARS

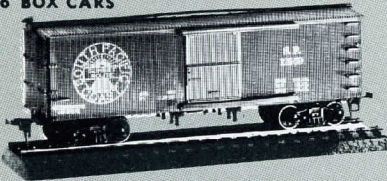

Cars are pre-painted Tuscan Red
B-361 Southern Pacific

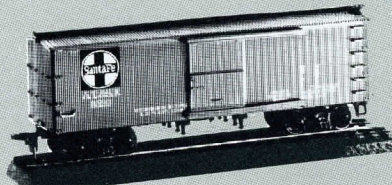

B-362 Santa Fe

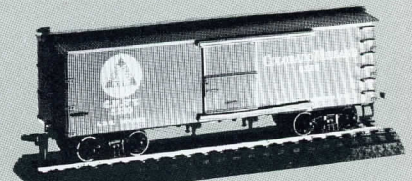

B-363 Colorado Midland

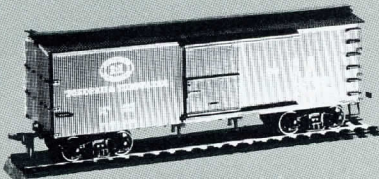

B-364 Tonopah & Tidewater

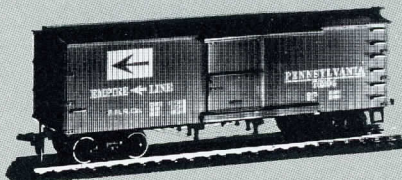

B-365 Pennsylvania

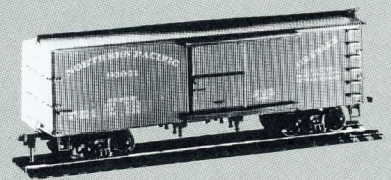

B-366 Northern Pacific

STOCK CARS

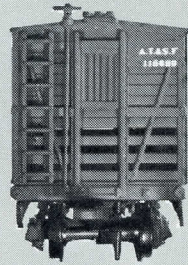
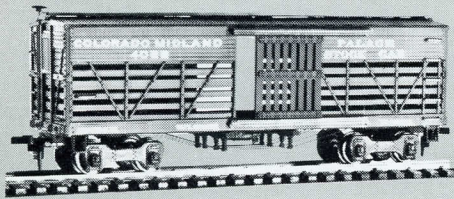

NEW S-367 Clinchfield-CC&O Box Car Red
 S-368 Colorado Midland Black
\$300 ea.

Each stock car is individually lettered and painted from official railroad prototype data.

These kits are complete with easy attaching hardware, plus additional detailing parts. You can produce many variations as found throughout the country on the prototype cars at the turn of the century. Individual metal grab irons and three plastic cast ladders, superdetailed doors and two types of early door guides and complete truss rod details are included with each kit. A cast metal underframe guarantees these stock cars to have unequalled rolling qualities, low center of gravity and correct weight without using extra pieces and hidden weights.

Unlettered S-36 Box Car Red

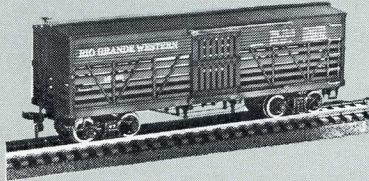

* S-361 Rio Grande Western

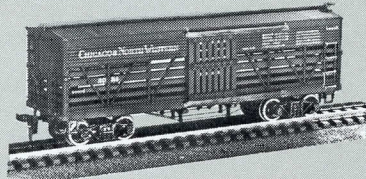

* S-362 Chicago Northwestern

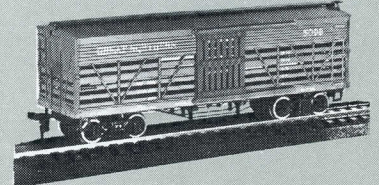

** S-363 Great Northern

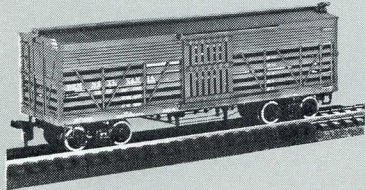

** S-364 Pennsylvania

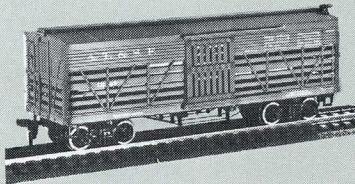

** S-365 Santa Fe

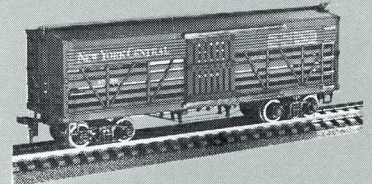

* S-366 New York Central

* Painted Black ** Painted Box Car Red

26' TANK CARS

\$375 T-26 Unlettered
 ea. Cars are pre-painted Black, with crisp white lettering

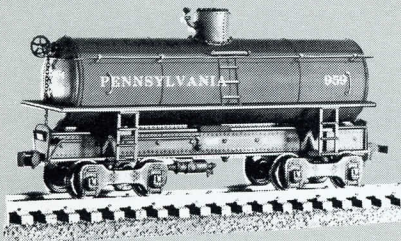

T-261 Pennsylvania

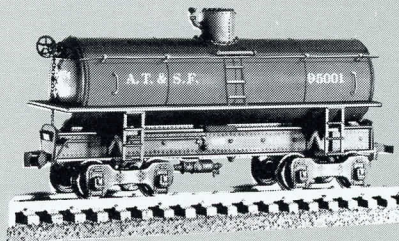

T-262 Santa Fe

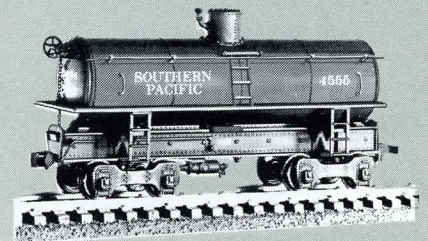

T-263 Southern Pacific

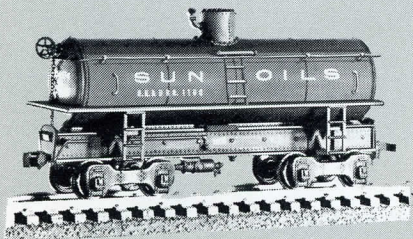

T-264 Sun Oils

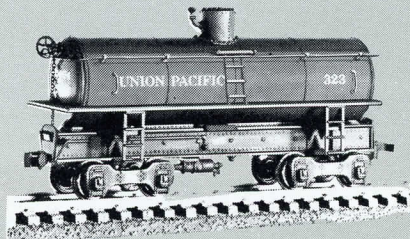

T-265 Union Pacific



T-266 Union Tank Line



OLD TIMER 34' CABOOSES

- ONE PIECE INJECTED MOLDED STYRENE BODY
- ATTACHABLE BRAKE WHEEL
- ATTACHABLE METAL GRAB IRONS
- KIT INCLUDES NMRA COUPLERS

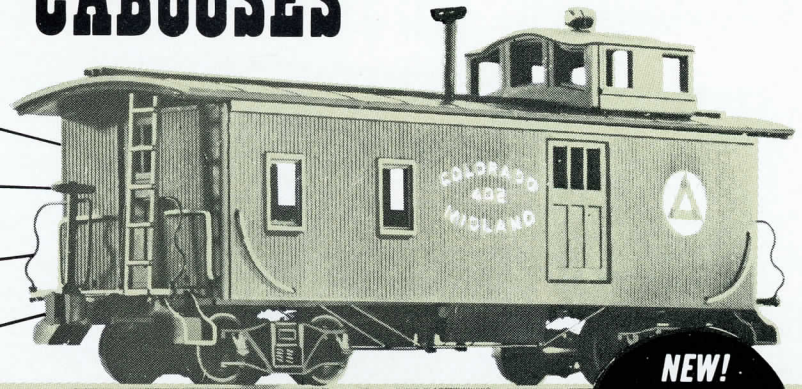

**NEW!
FEATURING
REMOVABLE
ROOF**

ROUNDHOUSE now has **24** of the most highly detailed, authentically scaled models ever produced.

Like the other "Old Timer" box cars, stock cars, reefers and tank cars we have been bringing out during the past year, these cabooses are easy to assemble, without any cutting or fitting needed. The engraved steel dies used in making these molded bodies provide the fine details and overall quality that makes them so realistic in appearance. Cars are pre-painted, with a contrasting roof, and lettered in a variety of road names. All attaching hardware is furnished, including grab irons, ladders, truss rods, old style roof top lantern, plus many others make this an outstanding, beautifully authentic model. Period trucks, with perfect rolling qualities that make operation a pleasure, are included in every kits.

\$3.75 ea.

SIDE DOOR, BLIND END C-20 Unlettered

C-200 Series represents one of the earliest styles of cabooses. Originally old box cars had windows and doors cut into their sides; this car is an out growth of such cars.

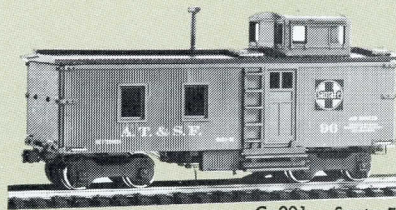

C-201 Santa Fe



C-202 Erie



C-203 Illinois Central



C-204 NYC

SIDE DOOR, OPEN END C-30 Unlettered

C-300 Series is an updated version side door caboose with an enlarged freight door and end platforms. End platforms were added because of trainmen being injured while climbing out of side doors in front of passing trains.



C-301 Baltimore & Ohio

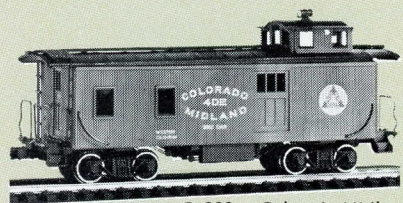

C-302 Colorado Midland

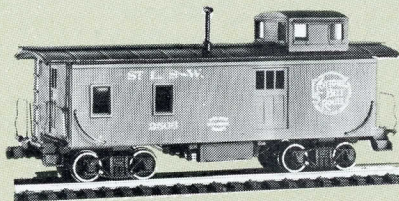

C-303 Cotton Belt- S.S.W.

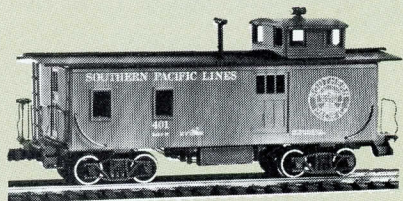

C-304 So. Pacific

3 WINDOW STANDARD
C-40 Unlettered

C-400 Series represents early 3 window standard cabooses. This caboose style was used from the early days right into the diesel era and may still be seen on short lines today.



C-401 Denver & R.G.W.



C-402 No. Pacific



C-403 Pennsylvania

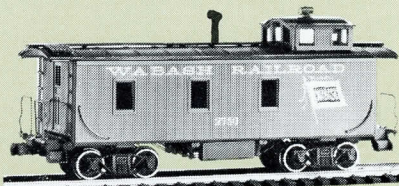

C-404 Wabash



C-405 So. Pacific



C-406 Reading



C-407 Canadian National

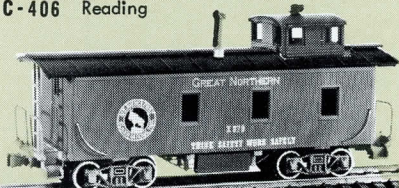

C-408 Great Northern

OUTSIDE BRACED

3460 Unlettered

3460 Series represents a standard style with truss sides giving the car additional strength. Again this style had wide acceptance with railroads across the country.



3461 M.K.T.

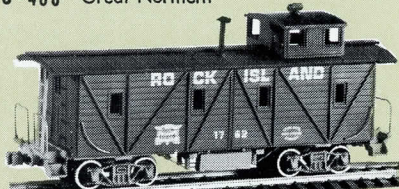

3462 Rock Island



3463 Western Pacific

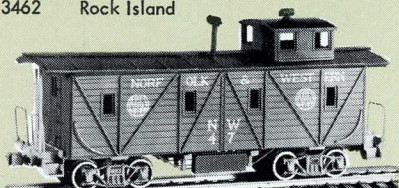

3464 Norfolk & Western

SMALL SIDE DOOR

3500 Unlettered

3500 Series is a variation of the early side door caboose with platforms and small side doors. This old truss rod caboose is one of the fore runner to our more modern day standard caboose.



3501 Union Pacific



3502 Atlantic Coast Line



3503 Chi. Burl. & Quincy



3504 Lehigh Valley

BOX CARS

AAR

The A. A. R. metal sheath type box car comprises about three quarters of the rolling stock of the nation's railroads. They range from very plain mineral red, quietly lettered in the majority of cases, to brilliant paint jobs and billboard size heralds.

\$2.50 ea.

B-4 Unlettered, A A R, Box Car Red

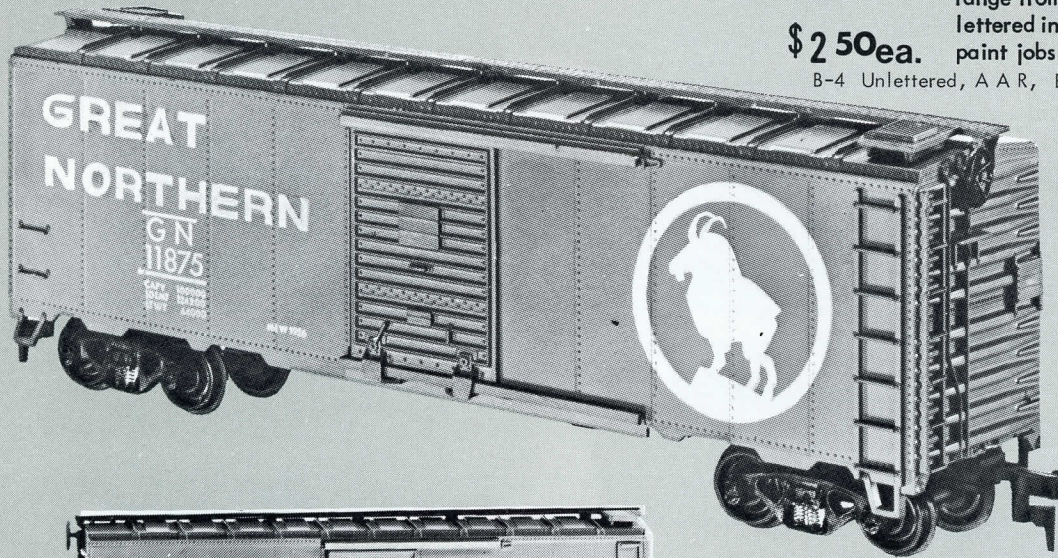

B-45

**GREAT
NORTHERN
BIG SKY
BLUE**

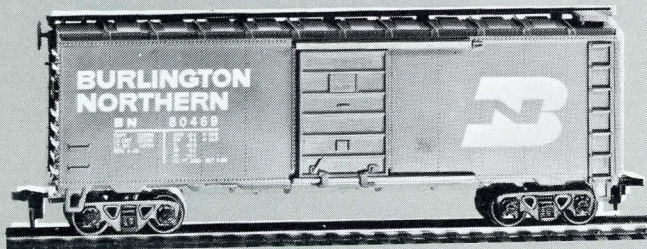

B-41 Burlington Northern Grass Green.

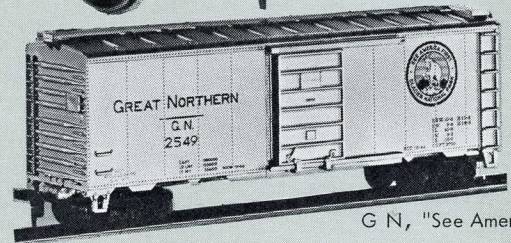

B-47
G N, "See America First"
Silver

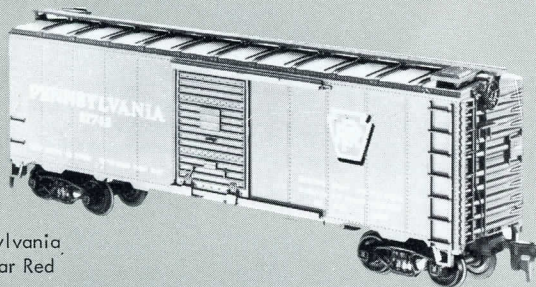

B-42
Pennsylvania
Box Car Red

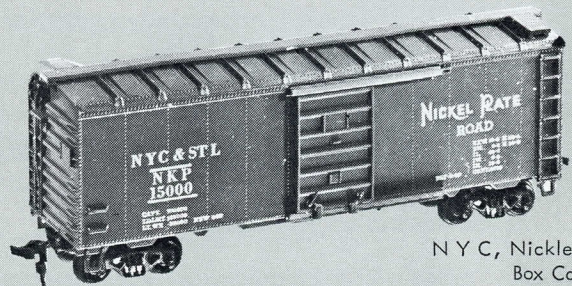

B-43
N Y C, Nickle Plate
Box Car Red

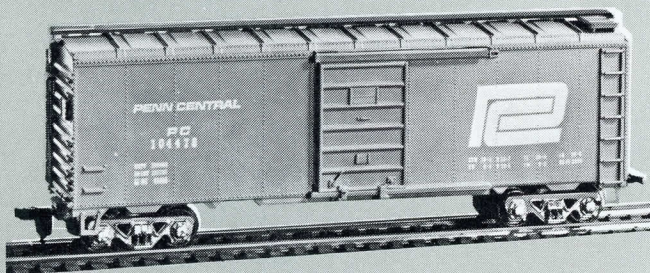

B-46 Penn Central P C Green

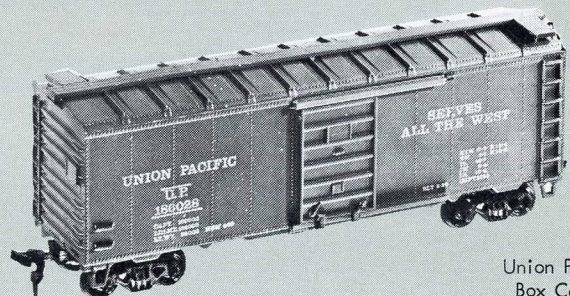

B-44
Union Pacific
Box Car Red

BOX CARS

TRUSS SIDE — HORIZONTAL RIB

Truss side box cars go back many years in their origin, but are still very much in use on today's railroads. Look at any long string of cars and you will probably see several truss side cars in a variety of road names, for most railroad lines own cars of this style.

B-3 Unlettered Truss Side

Horizontal Rib box cars are unique in design and are original with the Milwaukee Railroad. Properly, the reference should be Chicago, Milwaukee, St. Paul and Pacific Railroad Company. Freight equipment markings of C.M. St. P. & P. or The Milwaukee Road are found on the prototypes.

\$250 ea.

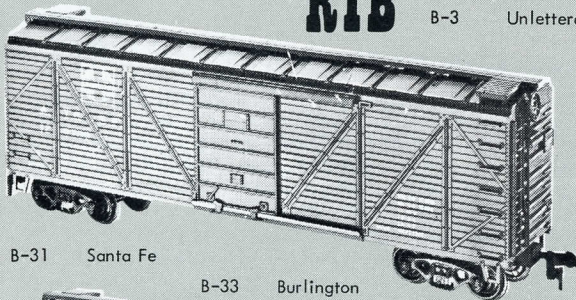

B-31 Santa Fe

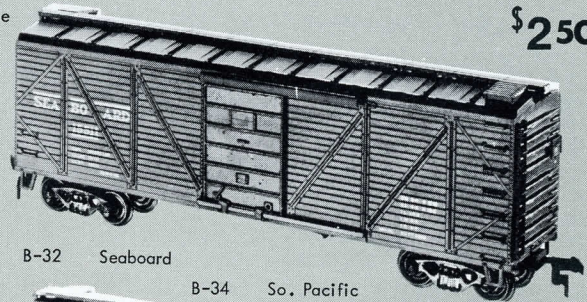

B-32 Seaboard

B-33 Burlington

B-34 So. Pacific

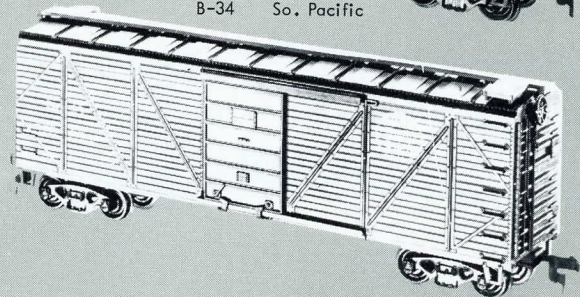
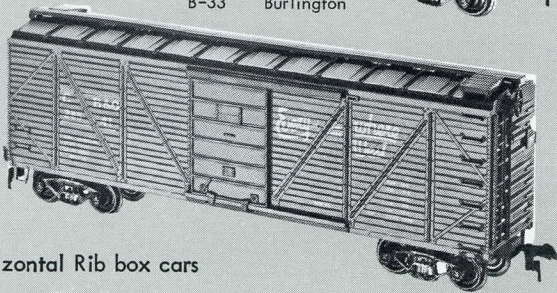

Horizontal Rib box cars

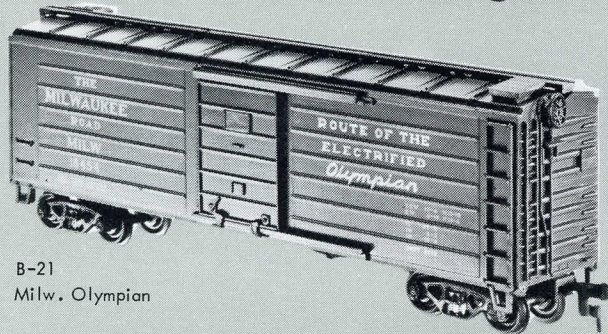

B-21
Milw. Olympian

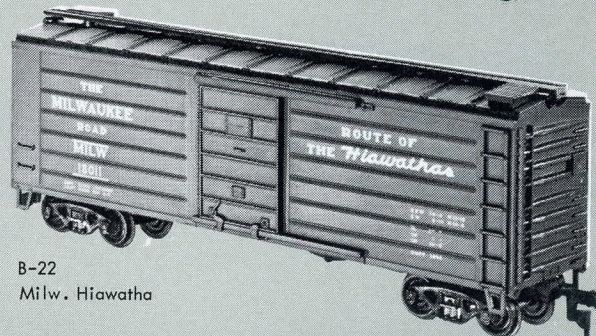

B-22
Milw. Hiawatha

CABOOSES 2 & 4 WINDOW

- | | | | |
|------|---------------------|------|---------------------|
| C-1 | Unlettered 2 Window | C-13 | Burlington Northern |
| C-11 | Pennsylvania | C-14 | Penn Central |



\$275 ea.

MODERN series

In addition to serving as a means of observation, the caboose is kitchen, bath and bedroom for your train's crew. Spare lanterns and other signal materials are carried here, and this is the conductor's office area.

- | | | | |
|------|---------------------|------|---------------------------|
| C-2 | Unlettered 4 Window | C-21 | So. Pacific |
| C-23 | Great Northern | C-24 | Great North. Big Sky Blue |

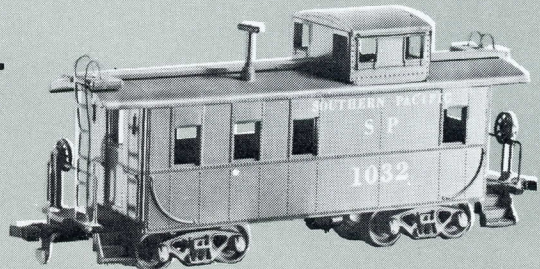

50' AAR BOX CAR

MODERN series

TIME-SAVER KITS

- Low center of gravity.
- One piece, injection molded body.
- Delrin trucks and RP25 wheels.

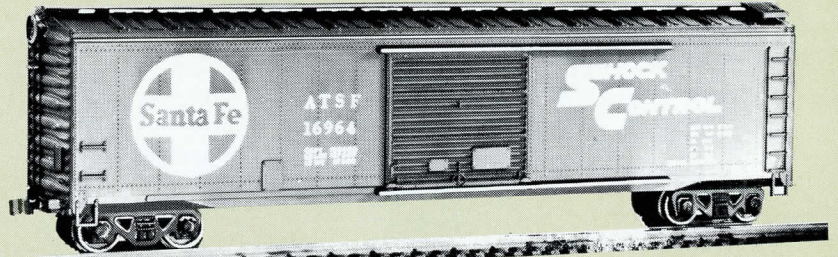

First Time Anywhere

\$2.50 ea.

This Roundhouse model is a reproduction of the relatively light weight box cars in use on rail lines everywhere, carrying almost every type of lading from coast to coast. It is known as an AAR Standard 50 Ton 50 Foot Steel Sheathed, Wood Lined Box Car, and may be seen in several door sizes, from six to fifteen feet. Our model has a ten foot door.

Each box car in this new series has been selected for "on-line" eye appeal. Multi-colored paint schemes and/or striping are carried completely across the door so no gap is left to obstruct the beauty of these cars from one end to the other. Individually painted in six outstanding road colors and finely printed with correct herald and reporting data.

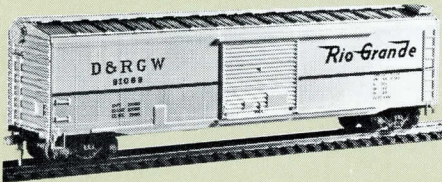

1201 Denver & Rio Grande

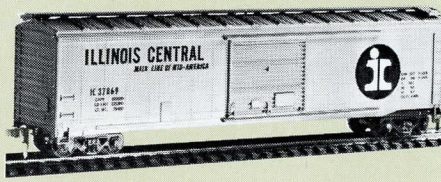

1202 Illinois Central

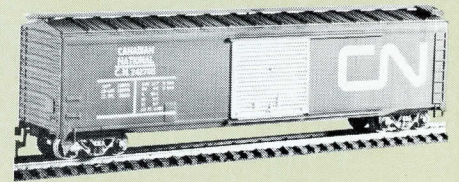

1203 Canadian National

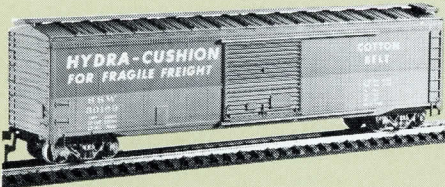

1204 Cotton Belt, S S W

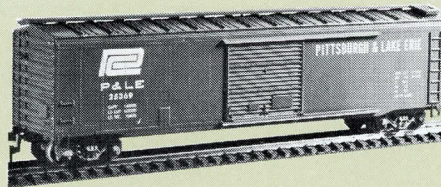

1205 Pittsburg & Lake Erie

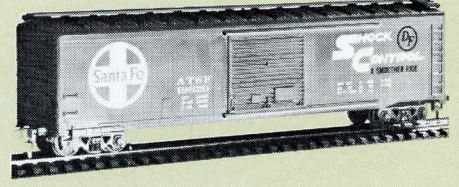

1206 Santa Fe

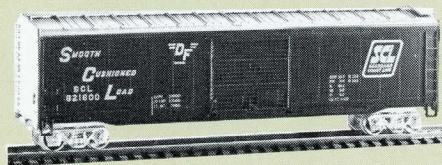

1207 Seaboard

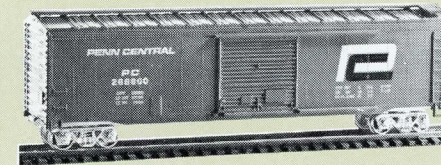

1208 Penn Central

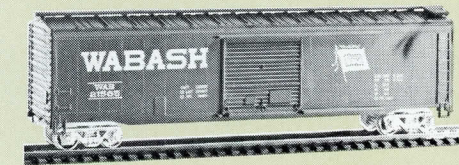

1209 Wabash

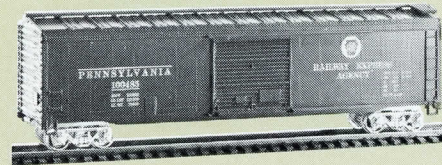

1210 Pennsylvania R.E.A.

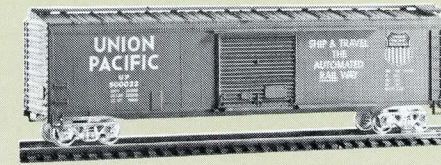

1211 Union Pacific

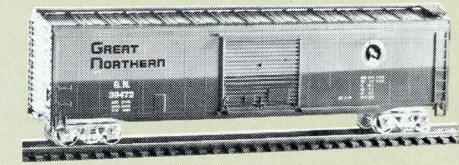

1212 Great Northern

1200 Unlettered

PLUG DOOR BOX CARS

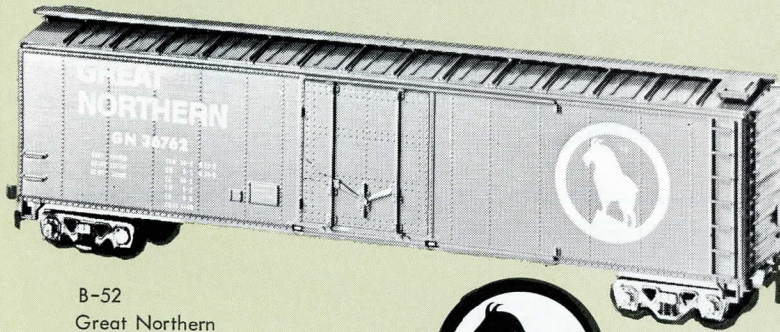

B-52
Great Northern
Big Sky Blue

PLUG DOOR 50' \$2.50 ea.

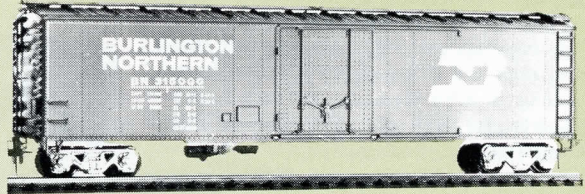

• B-51



**BURLINGTON
NORTHERN**

That's right - BURLINGTON NORTHERN - with the brand new color and herald set for the prototype cars of the merging Burlington and Great Northern. The clean, crisp white herald and reporting data set off the distinctive BN Green of the cars. See these fresh, cool grass green cars at your hobby shop now. Whether you run a matched set of these six models, or spot them among the more dusty looking reds and browns, you'll have tomorrow's look on your tracks today. Fast assembly, dependable performance, top quality - Roundhouse kits.

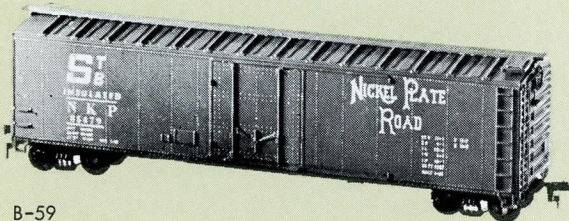

B-59
N Y C, Nickle Plate
Box Car Red

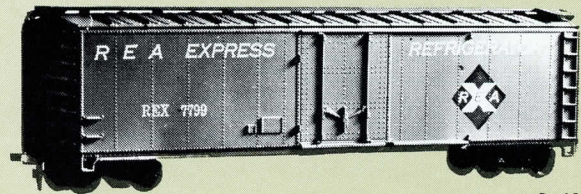

B-61
Railway Express
R E A Green

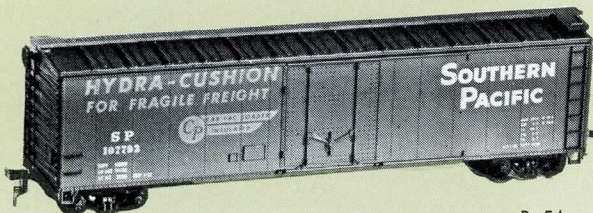

B-54
S P Hydro Cushion
Box Car Red

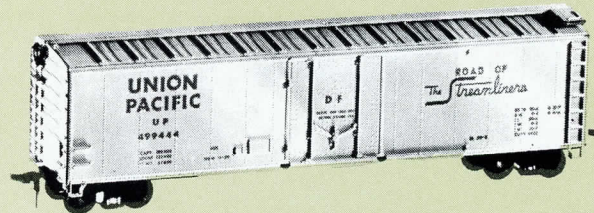

B-55
Union Pacific
Yellow

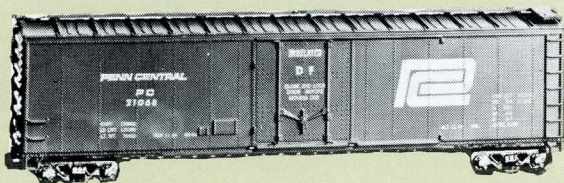

B-60
Penn Central
P C Green

B-5
Unlettered
Box Car Red

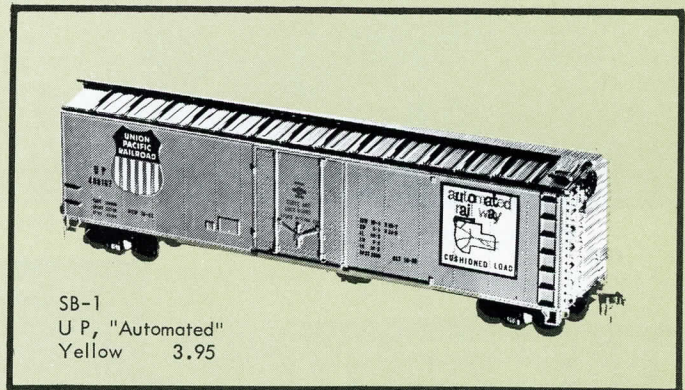

SB-1
U P, "Automated"
Yellow 3.95



GONDOLA

\$2.00ea.

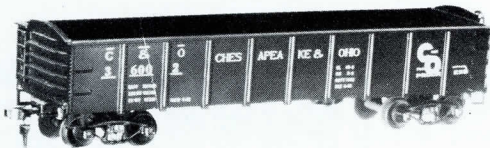

G-41 C & O Black

OVAL END GONDOLA

Here is an unusual Gondola with oval ends used by C & O in the days of yore. It's true to prototype and well detailed.

Designed for easy assembly. Molded in high impact styrene, factory painted and lettered. Complete with metal cast underframe, couplers and our super rolling trucks for trouble-free service.

Load these up with coal, iron ore, etc. for those long hauls. Remember, in the days of steam, it was a common sight to see as many as 200 of these gondolas rolling along the right-of-way.

FEATURING A COMPLETE LINE

G-4 Unlettered, Flat end, Box Car Red

G-42

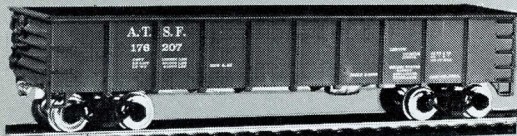

Box Car Red

G-43



Box Car Red

G-44

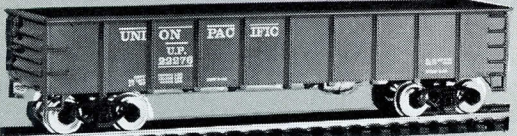

Box Car Red

G-45



Box Car Red

NEW

G-50

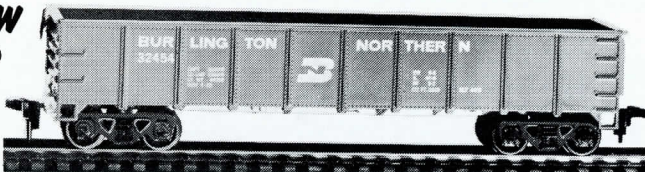

Grass Green

G-46

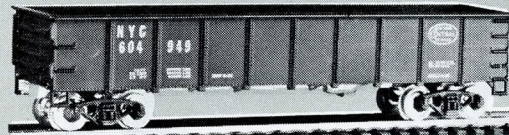

Black

G-47

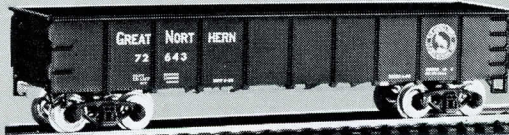

Black

G-48

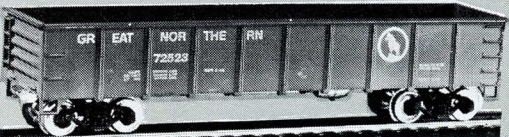

Big Sky Blue

G-49

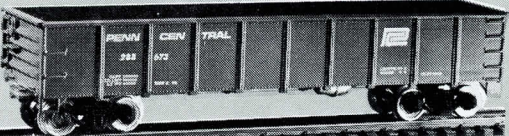

P C Green

30' FLAT CARS

Here is an appealing little car that has a variety of uses. It is designed to carry compact, heavy loads. Cars of this type were used in tandem during World War 1 to carry guns. The kit includes side boards so that it can be used as a gondola. You will find this car useful around your industrial and mining

operations; also, it makes a good logging car. This car may look delicate, but with the metal cast underframe to give it weight and strength, it is a very rugged car that will roll and track superbly. Painted and lettered for Milwaukee and Pennsylvania.

F-0 Unlettered Black

\$200 ea.

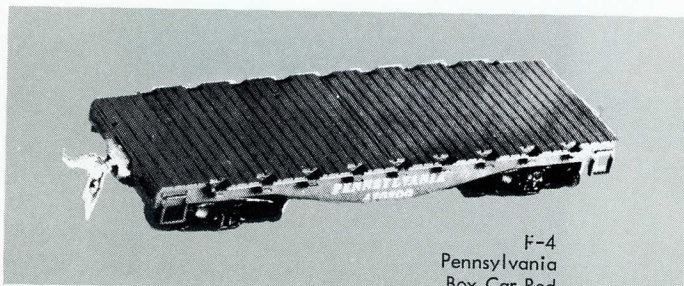

F-4
Pennsylvania
Box Car Red

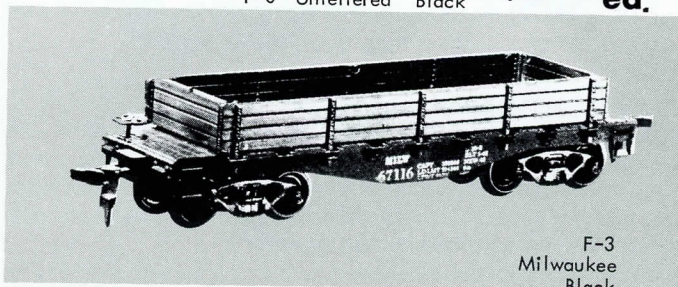

F-3
Milwaukee
Black

ORE CARS Available in two STYLES

A common, yet impressive sight in any mining area is a string of ore cars a mile or more long. A mine scene is ideal for a model railroad layout, and you will find these cars add the final touch of realism

\$200 ea. H-14 Southern Pacific

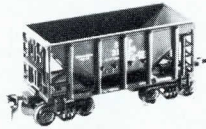

TAPERED SIDE

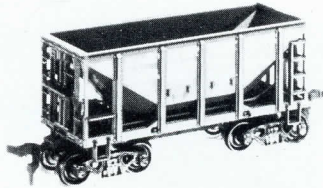

H-12
Chicago &
Northwestern

RECTANGULAR SIDE



H-24 Union Pacific

ORE CAR KITS TAPER SIDE

Tuscan Red

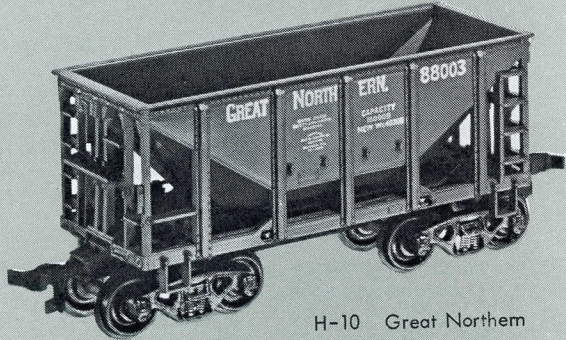

H-10 Great Northern

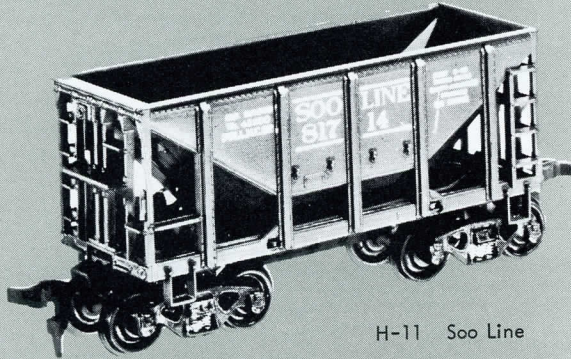

H-11 Soo Line

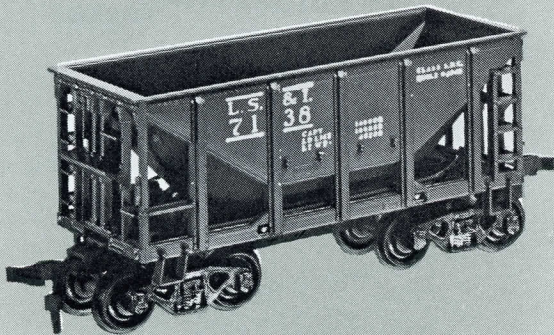

H-13 Lake Superior & Ishpeming

H-1 Unlettered

ORE CAR KITS RECTANGULAR SIDE

Tuscan Red

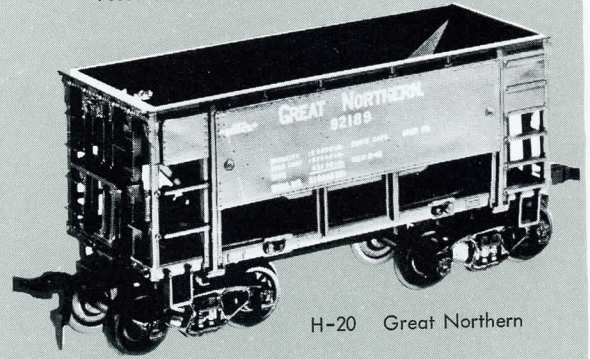

H-20 Great Northern



H-21 Duluth, Missabe & Iron Range

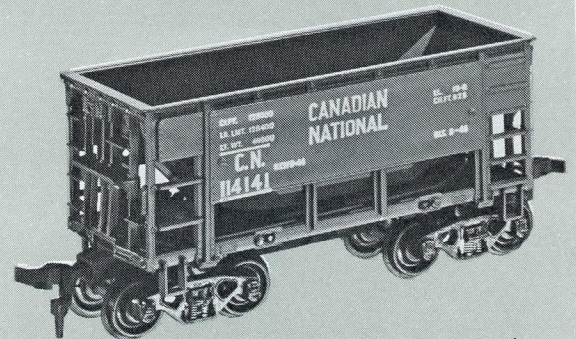

H-22 Canadian National

H-2 Unlettered

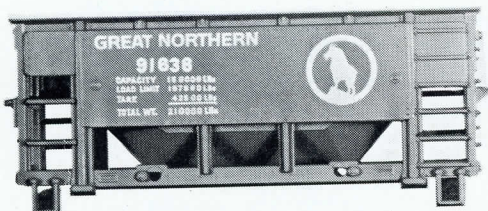

Great Northern H-25 Big Sky Blue

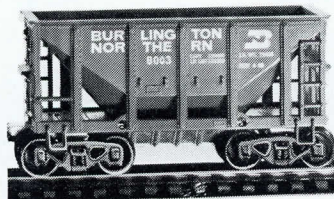

NEW
Grass Green
H-15 Burlington Northern

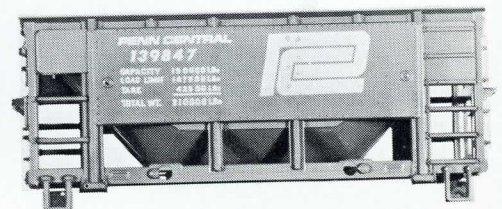

P C Green H-26 Penn Central

COVERED HOPPERS

MODERN

series
\$2.75 ea.



H-43 Burlington Northern Grass Green

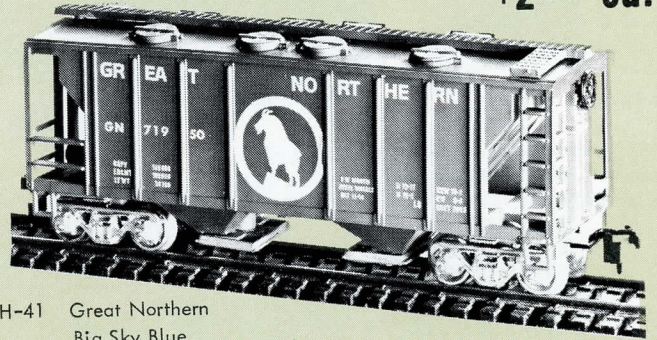

H-41 Great Northern
Big Sky Blue

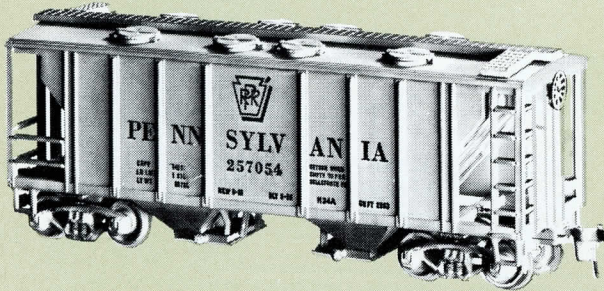

H-31 Pennsylvania

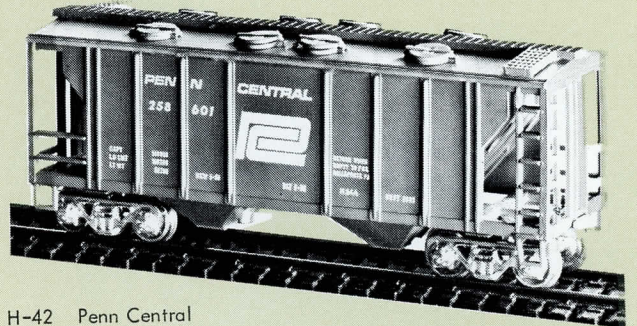

H-42 Penn Central
P C Green



H-32 Union Pacific

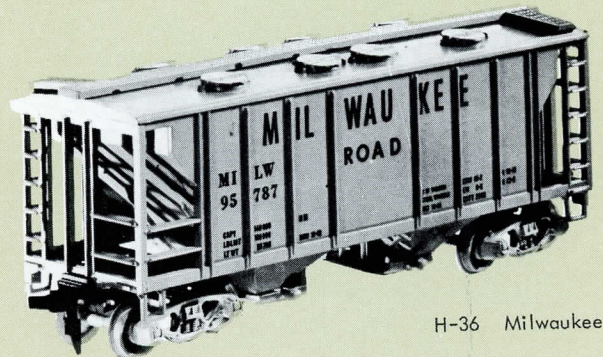

H-36 Milwaukee

H-35 Southern Pacific

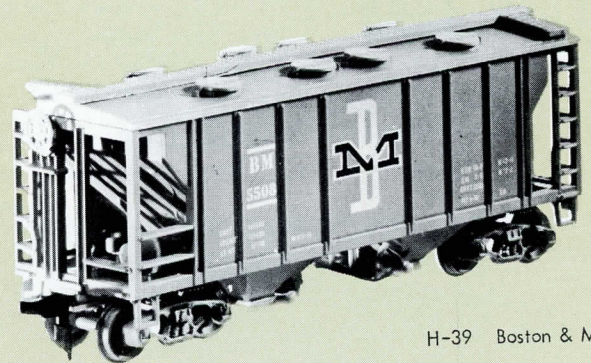
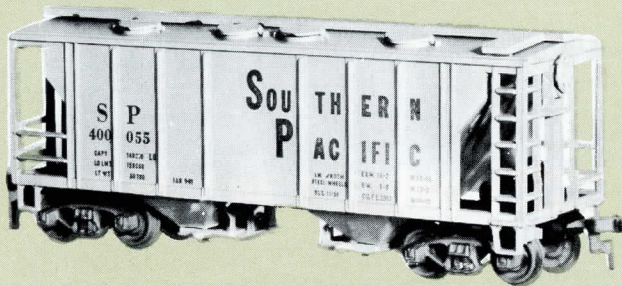

H-39 Boston & Maine
Blue

The first experimental covered hoppers were built more than forty years ago, but were not seen in very great numbers until the 1940's. Today there are over 70,000 of these cars in use, transporting more than 200 different types of granular commodities which must be kept dry and uncontaminated in transit.

H-3 Unlettered
Cement Grey

ROUNDHOUSE

★ NEW ★

SUPER ACTION DELRIN PASSENGER TRUCKS

These new super action, free rolling trucks feature self-centering coupler arm that swivels independently on the truck bolster. Truck may be used with or without swivel arm. Body bolsters are included. Trucks are a one piece molded frame with Delrin wheels and steel needle point axles. Designed for short radius curves and snaking through double switches.



2931 Std. Pullman, 6 wheel 1.00 pr

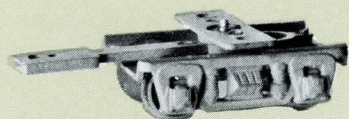

2932 Std. Pullman, 4 wheel .85 pr

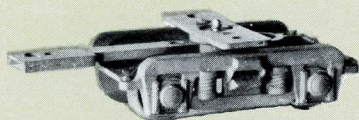

2933 Pennsy Roller Bearing .85 pr



2934 Challenger .85 pr



2935 Commonwealth .85 pr

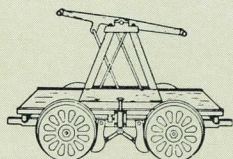

HH-100 Handcar kit, H O
1.00 ea

ACCESSORIES & EQUIPMENT

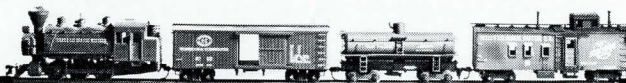

All Roundhouse kits, feature NEW one piece delrin RP-25 Super Quick Action trucks.

FREIGHT TRUCKS

.65 pr



TR 102 Arch Bar



TR 103 Bettendorf



TR 104 Fox



TR 105 Roller Bearing

MARKER LAMPS · H O

HX-900	3 green 1 red, caboose	.60 pr
HX-901	3 amber 1 red, caboose	.60
HX-902	2 green 2 red, switch stand	.60
HX-903	2 amber 2 red, switch stand	.60
HX-920	2 green 2 white, locomotive	.60

JEWELS · H O

HX-101	Red	.35 dz
HX-102	Green	.35
HX-103	Amber	.35
HX-104	White	.35
HX-100	White 3/16 diameter	.15 pr
HX-110	White 5/32 diameter	.15

O GAUGE

MARKER LAMPS

OX-900	3 green 1 red, caboose	.75 pr
OX-901	3 amber 1 red, caboose	.75
OX-902	2 green 2 red, switch stand	.75
OX-903	2 amber 2 red, switch stand	.75
OX-920	2 green 2 white, locomotive	.75

JEWELS

OX-101	Red	.35 dz
OX-102	Green	.35
OX-103	Amber	.35
OX-104	White	.35
OX-100	White 9/32 diameter, loco	.35 pr

MISC. H-O

CH-100	Knuckle coupler	.35 pr
CH-115	X2F, horn type	.35
HX-200	Track Gauge	
H O		.25 ea

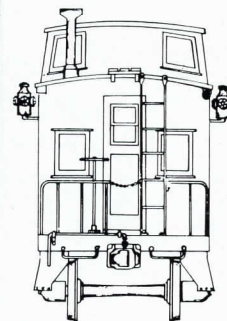

'O' GAUGE
COUPLERS

CO-200	Automatic Working coupler	1.00 pr
CO-210	Auto. Coupler with draft gear	1.35

Remember, only the finest quality HO kits roll with the name of Roundhouse. Next time you visit your local hobby dealer, ask him to show you each of our exciting kits. Roundhouse produces over 125 quality craftsman HO car kits and locomotive kits.

H-O DIESEL LOCOMOTIVES

SWITCHER PARTS

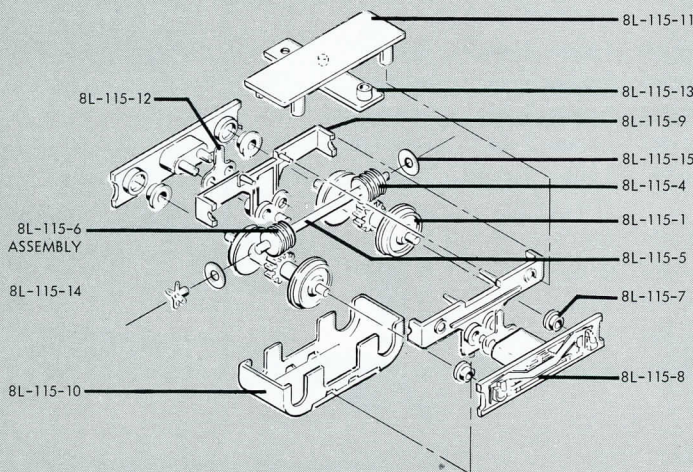
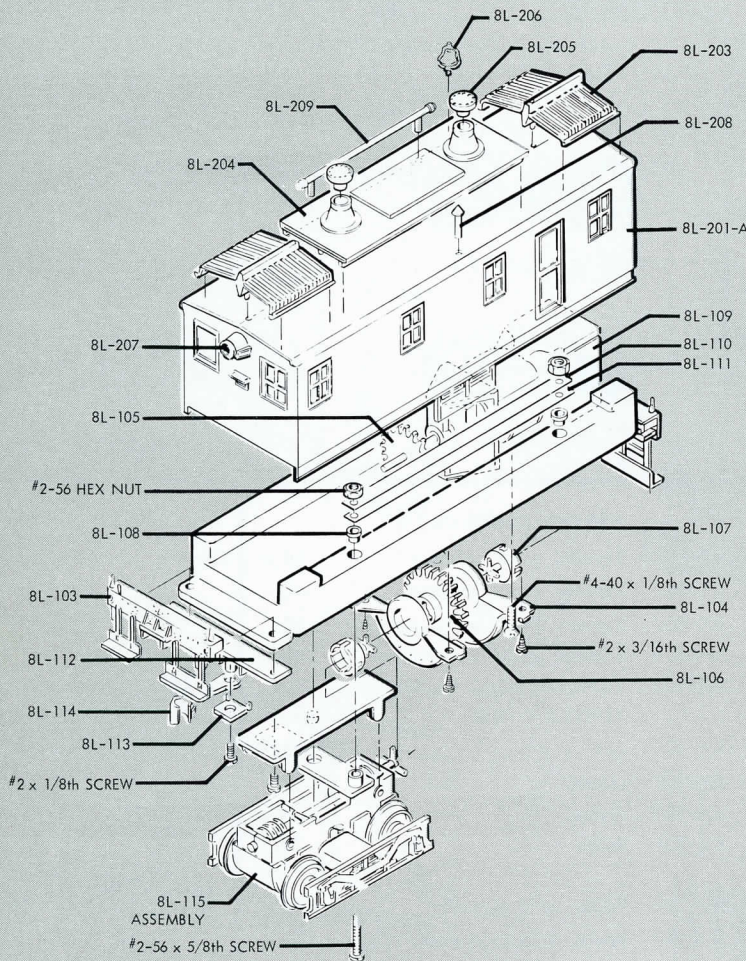

MECHANISM PARTS

8L-1	Diesel Locomotive	\$17.98
8L-101	Mechanism complete	15.00
8L-102	Underframe Die Cast	1.50
8L-103	End Bolster & Steps Includes coupler box & cover plate	1.25
8L-104	Gear Bracket	.75
8L-105	Gear Upper	.50
8L-106	Gear Lower	.50
8L-107	Universal Link	.50
8L-108	Insulator Bushing	.25
8L-109	Motor	7.00
8L-110	Jumper Bar Metal	.25
8L-111	Jumper Bar Fiber	.25
8L-112	Coupler Box Retainer	.50
8L-113	Coupler Cover Plate	.25
8L-114	Coupler	.35
8L-115	Power Truck Assembly	3.50
8L-115-1	Wheel Assembly	1.00
8L-115-4	Worm gear brass	.50
8L-115-5	Jack shaft	.25
8L-115-6	Jack Shaft & gear assembly	1.00
8L-115-7	Axle Bearing 4 pcs	.50
8L-115-8	Side frame die cast	.50
8L-115-9	Sub frame plastic	.50
8L-115-10	Retainer Bottom	.50
8L-115-11	Retainer Top	.50
8L-115-12	Pick-up arm	.50
8L-115-13	Mounting arm	.50
8L-115-14	Universal Driver	.50
8L-115-15	Washer	.50
8L-116	#2 x 1/8 th screw	.50
8L-117	#2 x 3/16 th screw	.50
8L-118	#2-56 x 5/8th screw	.75
8L-119	#4-40 x 1/8 th screw	.50
8L-120	#2-56 Hex nut	.50

SUPERSTRUCTURE PARTS

8L-201-A	Body Less end door	\$1.50
8L-202	Super structure kit	3.50
8L-203	Cooling Radiator	.75
8L-204	Platform	.75
8L-205	Exhaust Cover Plates	.50
8L-206	Bell	.50
8L-207	Head Light	.75
8L-208	Smoke Jack	.50
8L-209	Steam Line	.50

H-O LOCOMOTIVES PARTS

2-6-2 PRAIRIE

6L1 SERIES PRAIRIE KIT CONTENTS

MECHANISM PARTS

6L102	Underframe & Bearing Plate..	\$3.00 set
4L103	Yoke.....	2.00 ea.
4L104	Crosshead, 1 ea. of Left & Right.....	.60 set
6L106	Side Rod.....	.60 pr.
6L107	Main Rod.....	.90 pr.
4L108	Ladder Steps.....	1.25 ea.
4L113	Cylinder Block.....	1.25 ea.
6L126	Draft Gear Lid.....	.30 ea.
2L128	Worm Gear, 64P Brass.....	.90 ea.
6L151	Driver Assembly, Front Driver	3.00 ea.
6L152	Driver Assembly, Geared.....	3.90 ea.
6L153	Rear Driver.....	3.00 ea.
6L156	Driver Set, 1 ea. of 6L151, 6L152, & 6L153.....	9.90 set
6L160	Lead Truck.....	1.25 ea.
6L163	Trailer Truck assembly.....	1.25 ea.
2L120	Crank Pin Screw.....	.60 pr.

SUPERSTRUCTURE PARTS

4L200	Boiler.....	6.50 ea.
4L201	Air Tank.....	.40 pr.
4L202	Reverse Cylinder.....	.40 ea.
4L203	Number Board.....	.40 ea.
4L204	Piping.....	.40 ea.
4L250	Cab.....	2.50 ea.
2L205	Compressor.....	.50 ea.
2L211	Handrail Posts.....	1.20 doz.
2L218	Handrail Wire.....	.35 ft.

TENDER PARTS

4L301	Body.....	4.50 ea.
4L303	Barrel.....	.40 ea.
4L304	Draft Gear Lid.....	.30 ea.
2L302	Draw-bar, fibre.....	.30 ea.

MISCELLANEOUS PARTS

TR-300	Andrews Trucks.....	\$1.35 pr.
TR-303	Arch-Bar Trucks.....	1.35 pr.
CH-111	NMRA Auto. Couplers.....	.35 pr.
#2x3/16"	Rd. Hd. Self-tapping Screws.....	.40 doz.
#2x1/4"	Rd. Hd. Self-tapping Screws.....	.40 doz.
#2x5/16"	Button Hd. Self-tapping Screws.....	.40 doz.
#2x3/16"	Button Hd. Self-tapping Screws.....	.40 doz.
#0x1/8"	Rd. Hd. Self-tapping Screws.....	.40 doz.
#3x1/2"	Rd. Hd. Machine Screw.....	.40 doz.
#2x3/4"	Rd. Hd. Machine Screw.....	.40 doz.
#00x3/16"	Optical Screw.....	.40 doz.
#2	Hex. Nut.....	.40 doz.

VALVE GEAR PARTS

4L400	Valve Rod.....	.30 ea.
4L401	Combination Lever.....	.30 ea.
4L402	Crosshead Link.....	.30 ea.
4L403	Radius Rod.....	.30 ea.
4L404	Link.....	.30 ea.
6L405	Eccentric Rod.....	.30 ea.
4L406	Rivets, small for linkage...	.30 ea.
6L407	Eccentric Crank.....	.30 ea.
2L125	Rivet, large for Ec. Crank linkage.....	.40 ea.
6L020	Valve Gear Set, all of above listed parts necessary to make complete valve gearing.	5.75 set

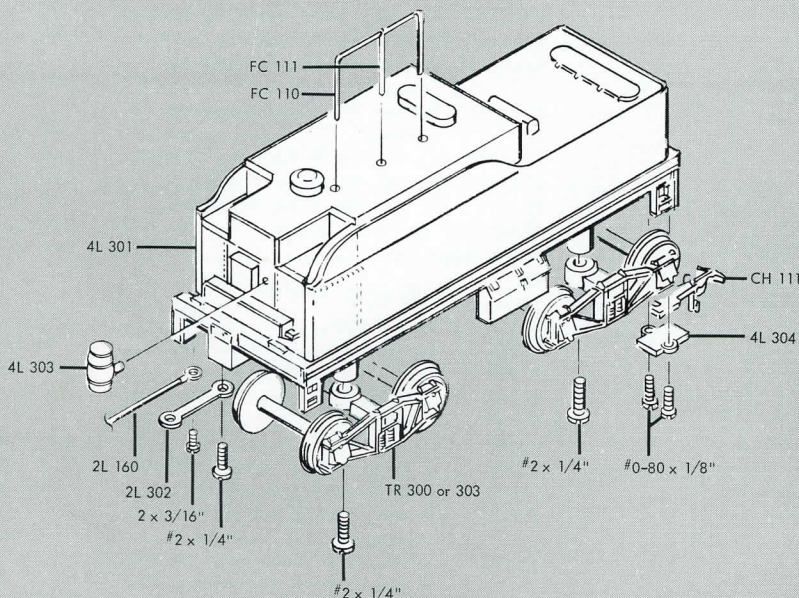
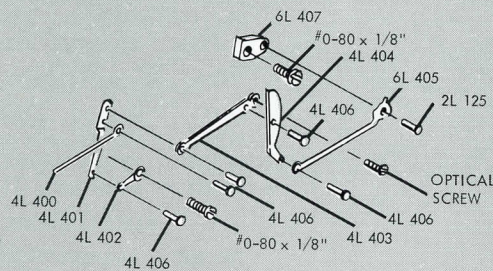
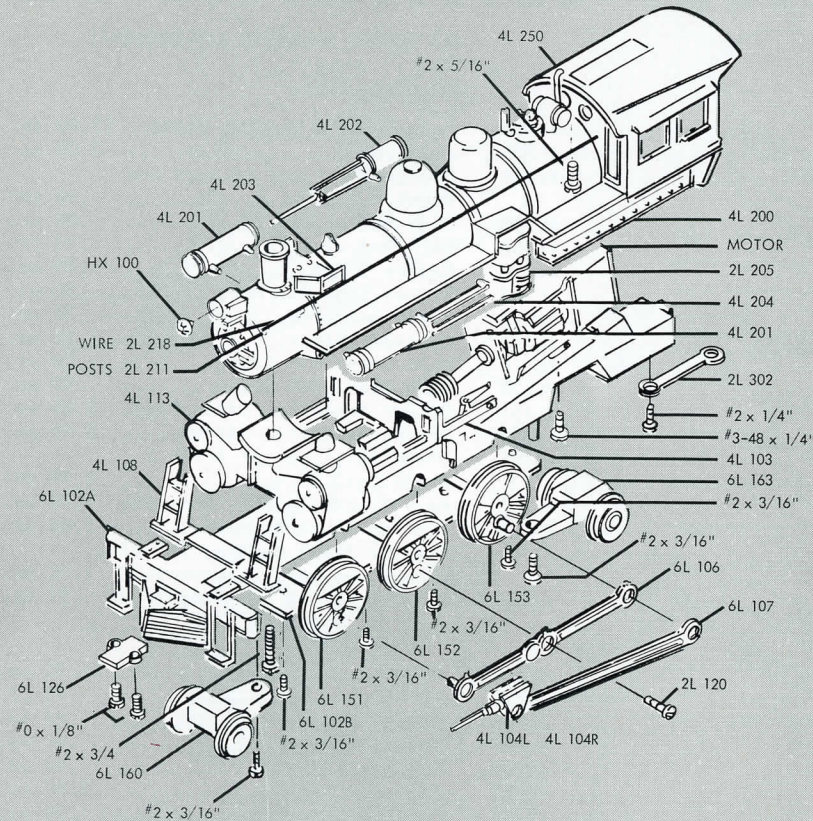

H-O LOCOMOTIVES PARTS

4-4-2 ATLANTIC

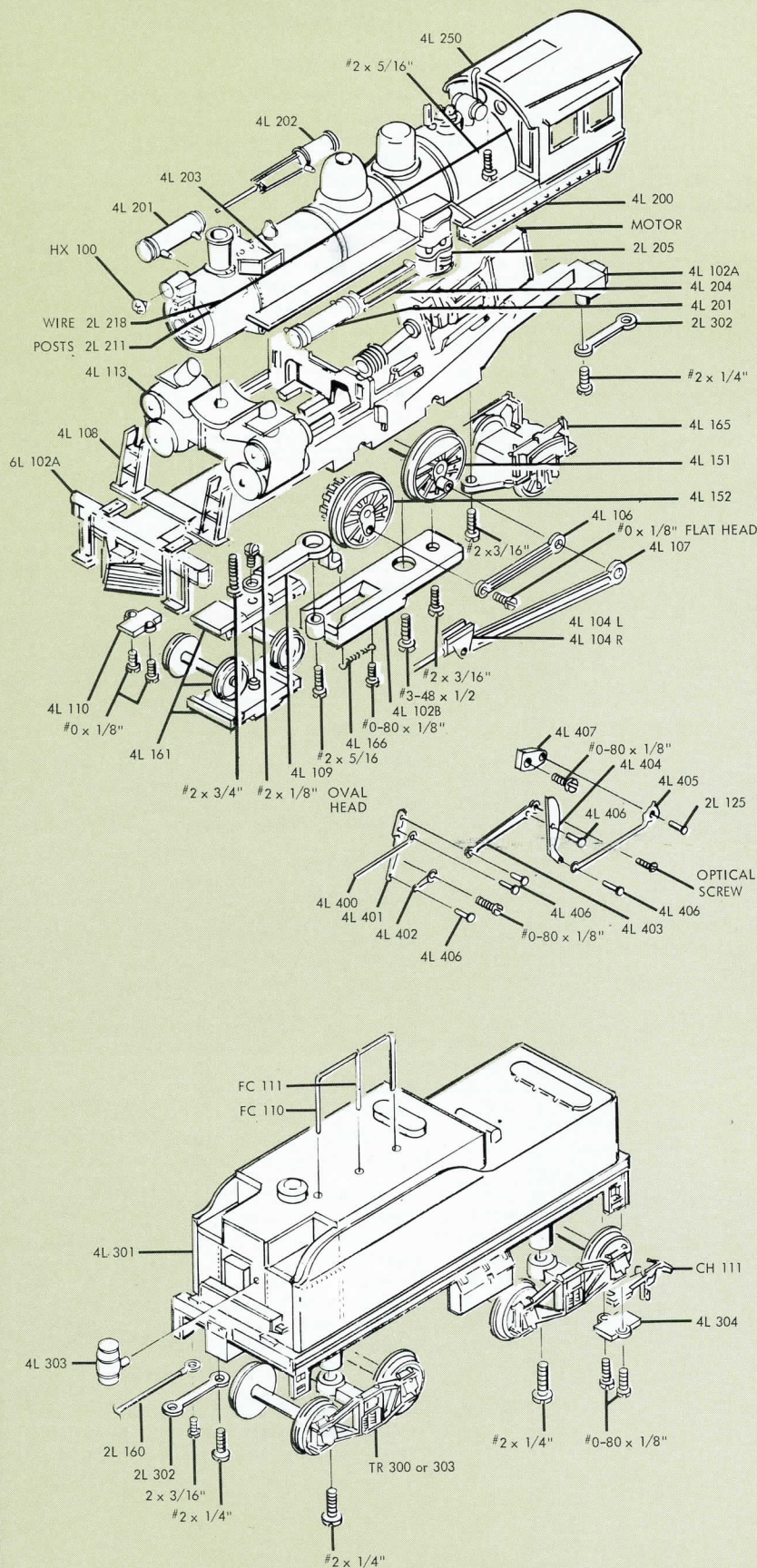

4L1 SERIES ATLANTIC KIT CONTENTS

MECHANISM PARTS

4L102	Underframe & Bearing Plate..	\$3.00
4L103	Yoke.....	2.00
4L104	Crosshead, 1 ea. of Left and Right.....	.60
4L106	Side Rod.....	.60
4L107	Main Rod.....	.90
4L108	Ladder Steps.....	1.25
4L109	Swivel Link for Pony Truck..	.50
4L110	Draft Gear Lid.....	.30
4L113	Cylinder Block.....	1.25
4L119	Main Crank Pin Stud.....	.50
2L128	Worm Gear, 64P Brass.....	.90
4L151	Driver Assembly, Idler type.	3.00
4L152	Driver Assembly, Geared.....	3.90
4L156	Driver Set, 1 ea. of 4L151 & 4L152.....	6.90
4L160	Pony Truck Assembly complete	1.50
4L163	Trailer Truck Assembly.....	3.00
4L165	Trailer Truck Wheels, 51" dia. spoked, assembly.....	1.10
4L166	Tension Spring for Pony Truck	.35

SUPERSTRUCTURE PARTS

4L200	Boiler.....	\$6.50
4L201	Air Tank.....	.40
4L202	Reverse Cylinder.....	.40
4L203	Number Board.....	.40
4L204	Piping.....	.40
4L250	Cab.....	2.50
2L205	Compressor.....	.50
2L211	Handrail Posts.....	1.20
2L218	Handrail Wire.....	.35

TENDER PARTS

4L301	Body.....	4.50
4L303	Barrel.....	.40
4L304	Draft Gear Lid.....	.30
2L302	Draw-bar, fibre.....	.30

MISCELLANEOUS PARTS

TR-300	Andrews Trucks.....	1.35
TR-303	Arch-bar Trucks.....	1.35
CH-111	NMRA Auto. Couplers.....	.35
#2x3/16" Rd. Hd. Self-tapping Screws		.40
#2x1/4" Rd. Hd. Self-tapping Screws		.40
#2x5/16" Button Hd. Self-tapping Screws.....		.40
#2x3/16" Button Hd. Self-tapping Screws.....		.40
#0x1/8" Rd. Hd. Self-tapping Screws		.40
#3x1/2" Rd. Hd. Machine Screw.....		.40
#2x3/4" Rd. Hd. Machine Screw.....		.40
#00x3/16" Optical Screw		.40
#2 Hexagon Nut.....		.40

VALVE GEAR PARTS

4L400	Valve Rod.....	.30
4L401	Combination Lever.....	.30
4L402	Crosshead Link.....	.30
4L403	Radius Rod.....	.30
4L404	Link.....	.30
4L405	Eccentric Rod.....	.30
4L406	Rivets, small for linkage..	.30
4L407	Eccentric Crank.....	.30
2L125	Rivet, large for Ec. Crank linkage.....	.40
4L020	Valve Gear Set, all of above listed parts necessary to make complete valve gearing	5.75

PULLMAN PALACE CARS

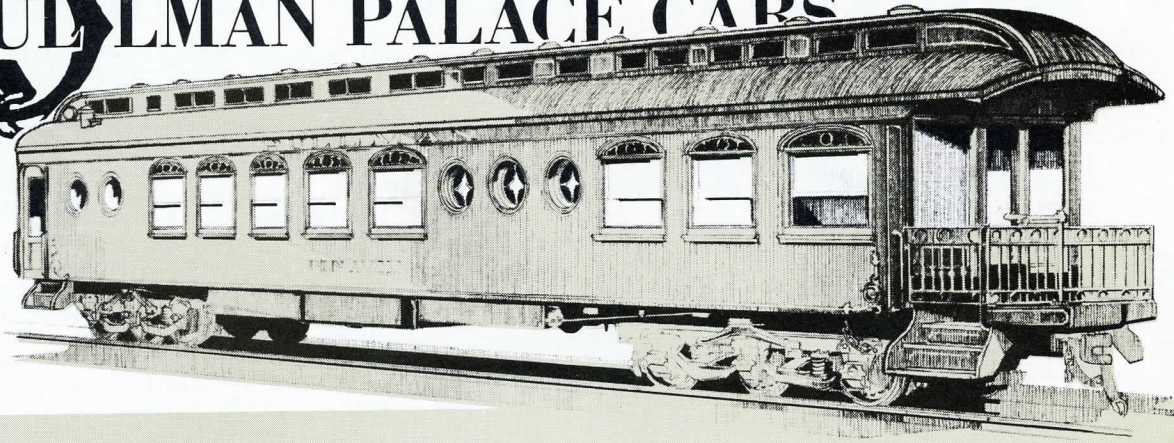

"VARNISH" FROM THE "GOLDEN AGE" OF RAILROADING

Start collecting these elegant scale reproductions of yesteryear - four fabulous all wooden type Pullman Passenger Cars. Dining Car, Compartment Sleeper, Combination and the grand splendor of the Pullmans, a magnificent Observation Car. Prepainted one-piece molded body with separate attaching details - ventilators, tinted celestary window material, plus truss rods, queen posts, water and air tanks, etc. for complete undercarriage details. To finish your classic model, kit includes an easy to apply Gold Rub-on Transfer with several road names, car numbers, lines, scroll work and filigree for arch and oval windows. Trucks and couplers included.

COMPARTMENT SLEEPING CAR
P-81

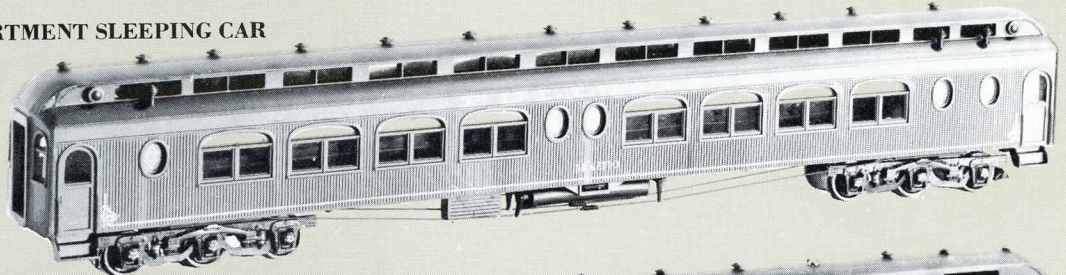

OBSERVATION CAR
P-82



COMBINATION CAR
P-83

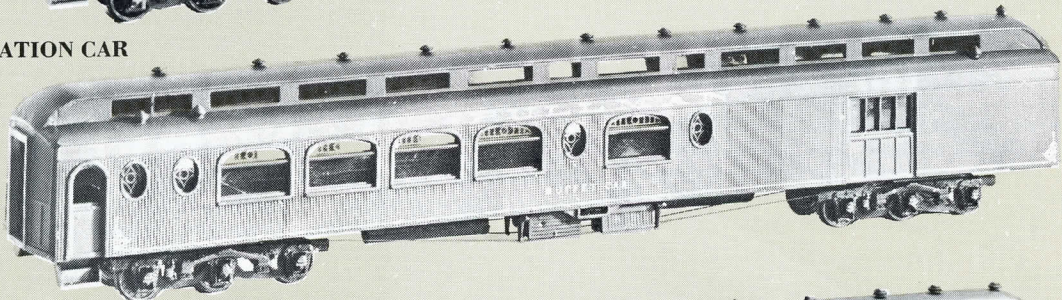

DINING CAR
P-84

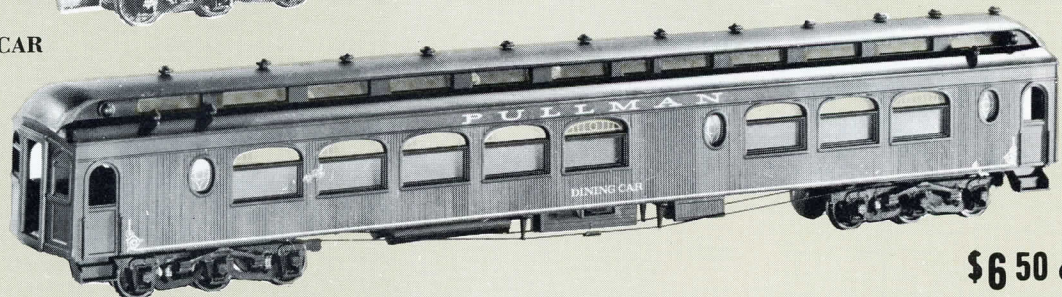

\$6.50 ea.

NEW '50' SLEEPING & BAGGAGE PULLMAN'S PALACE CARS

With the completion of the transcontinental overland route; a new era in passenger travel was born, the "overnight Pullman sleeping car". This car was longer, higher, and wider than predecessors. Here first came the folding upper berth; two compartments at each end with eight sections, fully carpeted, french plush upholstery, finished in "vamish".

Roundhouse has re-created the 50' Pullman Coach and Baggage. Kits are engineered for home layouts or club, with long throw self centering toggle couplers, and all Delrin four wheel Pullman Trucks. Both style of car kits are pre-painted in matching two color combinations; printed with all appropriate lettering and scrolls. Body is a one piece molding with separate attaching hardware

\$4.95 ea.

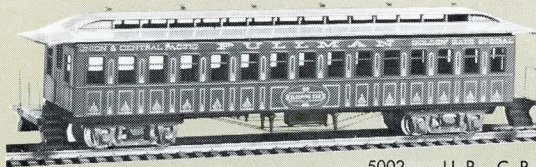

5002 U.P. C.P.



5022 U.P. C.P.



5003 New York Central

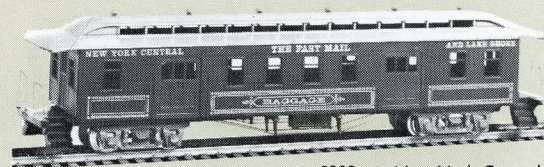

5023 New York Central



5004 Santa Fe



5024 Santa Fe

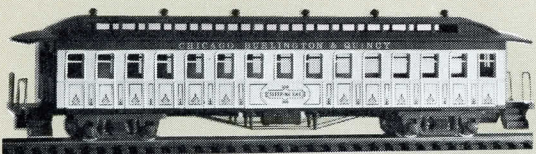

5005 Chicago, Burlington & Quincy



5025 Chicago, Burlington & Quincy

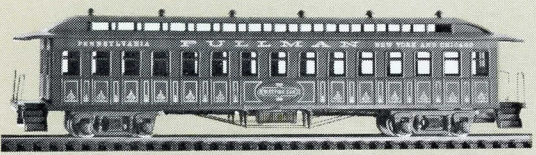

5006 Pennsylvania

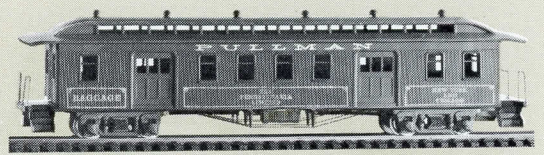

5026 Pennsylvania

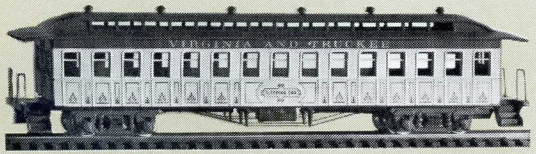

5007 Virginia & Truckee

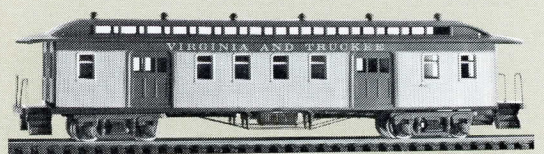

5027 Virginia & Truckee

50' PASSENGER CAR
5001 Unlettered

50' BAGGAGE
5021 Unlettered

NEW! ROUNDHOUSE OLD TIMER CIRCUS ADVERTISING CARS



A GRAND OLD DAY AT THE CIRCUS. Of course you went to the circus as a boy and have fond memories of the High Wire Acrobats - The Master of ceremonies - The Tent Show Barkers - The Wild Animals - The Colorful Clowns etc. Bring this all back now on your Railroad Empire with these new blazing colorful, eye catching cars - Right out

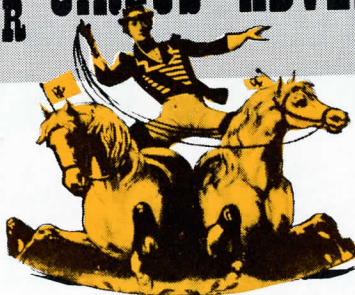

of the days of yore. Cars are painted and lettered in blazing authentic color. Beautifully detailed. Make up a circus train for your layout or make a mantle or shadow box display. They would make a extra nice gift for that special occasion. These cars come complete, with trucks and couplers, nothing else to buy. Easy to assemble, operates on any H-O scale track and with all other H-O scale equip.

\$4.95 ea.



5046 Barnum & Bailey



5036 Barnum & Bailey

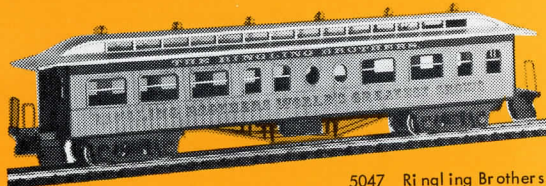

5047 Ringling Brothers



5037 Ringling Brothers

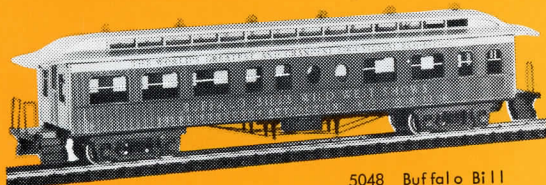

5048 Buffalo Bill

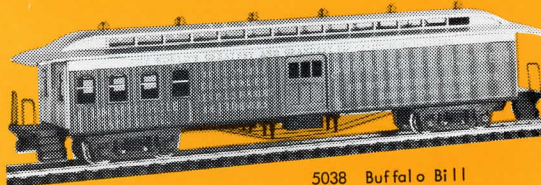

5038 Buffalo Bill

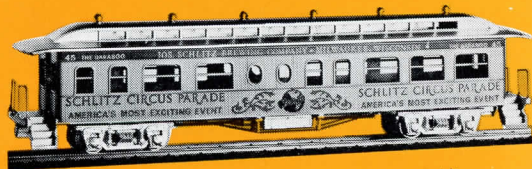

5049 Jos Schlitz

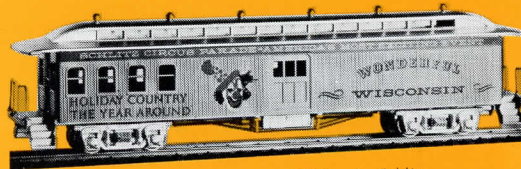

5039 Jos Schlitz

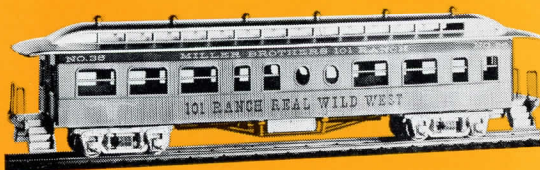

5050 101 Ranch

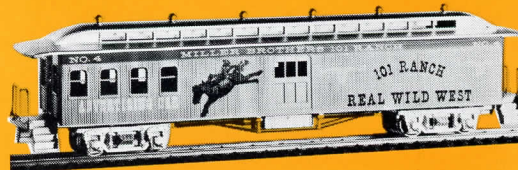

5040 101 Ranch

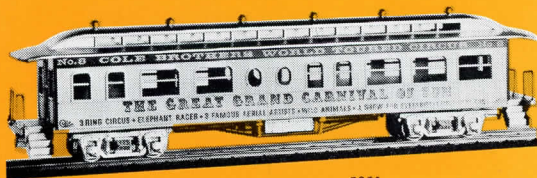

5051

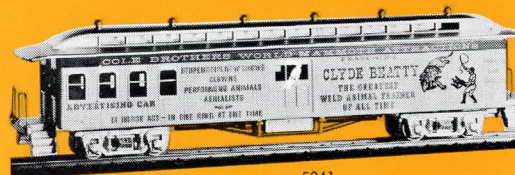

5041

BUSINESS CARS
5045 Undecorated

COMBINATION CARS
5035 Undecorated

New

HARRIMAN Passenger Car Series

NOW---ROUNDHOUSE Products, the manufacture who produce only the finest in H-O Scale Model Railroad equipment, proudly presents the HARRIMAN style passenger car series. Each model in this new series is engineered from official Comman Standard Car Company blue prints, Circa 1910.

These beauties were designed for either your favorite "HI BALL" steamer or your modern diesel locomotive. Cars

are equipped with long throw toggle couplers for minimum radius home layouts or Hi Baling on your big club pike. 'Slickest' rolling trucks made! Scale Pullman 4 wheel trucks with NMRA wheel sets. Kits come complete with underbody detailing & separate attaching roof, for easy interior detailing. The finished body is attractivly painted in two colors, individually printed Kits operate with all H-O scale equipment.

\$4.95 ea



6001 - Southern Pacific



6003 - Pennsylvania



6011 - Southern Pacific



6013 - Pennsylvania



6021 - Southern Pacific



6023 - Pennsylvania



6002 - Chicago & Northwestern

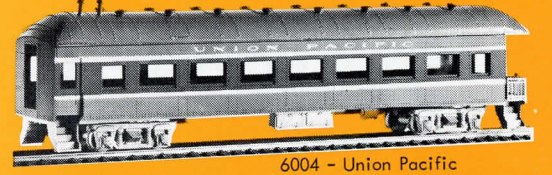

6004 - Union Pacific



6012 - Chicago & Northwestern

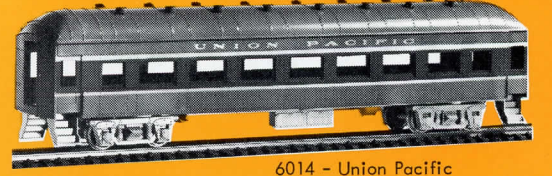

6014 - Union Pacific



6022 - Chicago & Northwestern



6024 - Union Pacific

6000 - Undecorated **OBSERVATION**

6010 - Undecorated **COACH**

6020 - Undecorated **BAGGAGE**

34' OVERTON series BUSINESS COACH COMBINE BAGGAGE

\$3.75
ea.

Overland Dispatch
The Fast Mail

Denver Rio Grand Western

Union Pacific

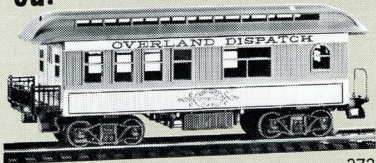

3731

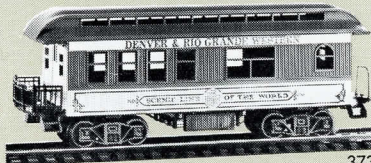

3732

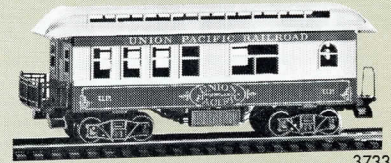

3733



3701

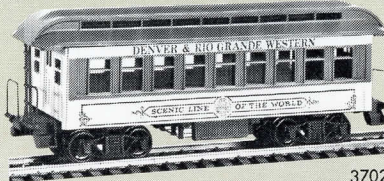

3702

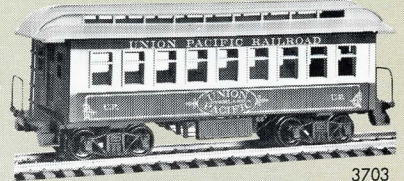

3703



3721

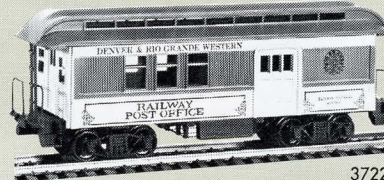

3722



3723

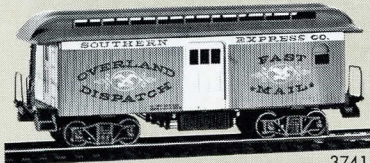

3741

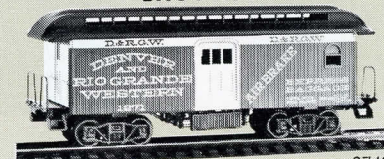

3742



3773



3734

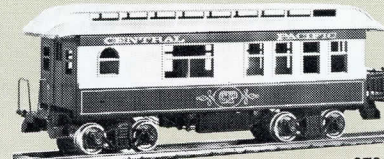

3735

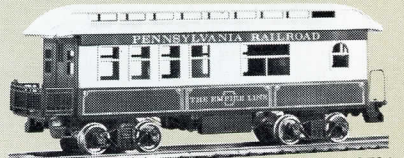

3736

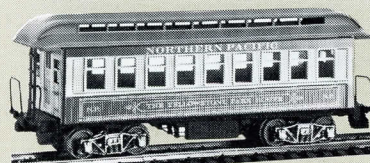

3704

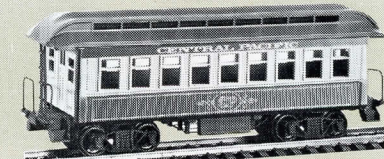

3705



3706



3724

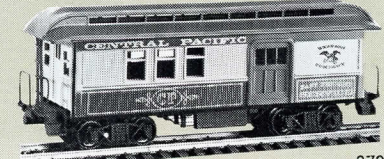

3725



3726



3744



3745

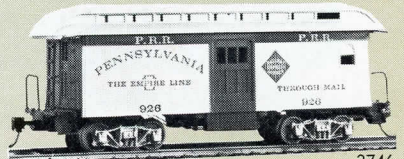

3746

Northern Pacific

Central Pacific

Pennsylvania

BUSINESS CAR Unlettered 3730

COACH Unlettered 3700

COMBINE Unlettered 3720

BAGGAGE Unlettered 3740

50' EXPRESS REFRIGERATOR CARS

The express refrigerator cars were used in passenger trains to move perishable goods, which in most cases meant overnight delivery versus several days in regular freight service. This is a beautiful car, designed for easy assembly, with removable roof and underframe. Kit is complete with trucks and couplers, pre-painted and lettered in popular road names. Operates on all HO scale railroads and is interchangeable with all other HO scale equipment.



375
ea.

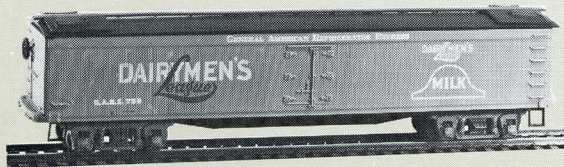

3607 Dairymen's League



3608 Central Vermont

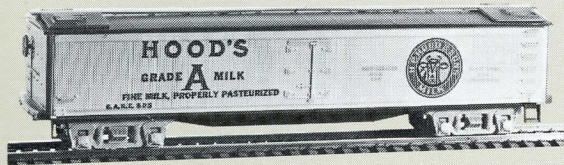

3609 Hood's Milk

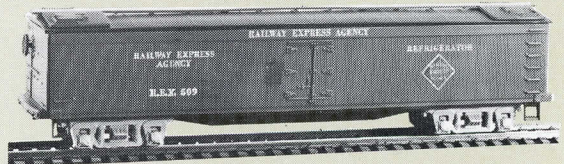

3610 Railway Express Agency

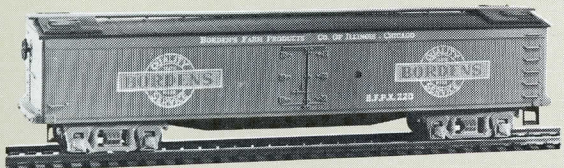

3611 Borden's Milk



3612 Chateau Martin Wine

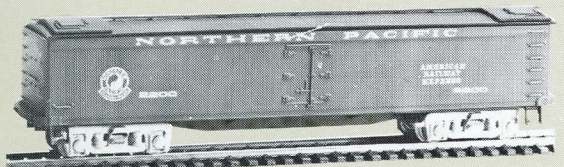

#3601 Northern Pacific

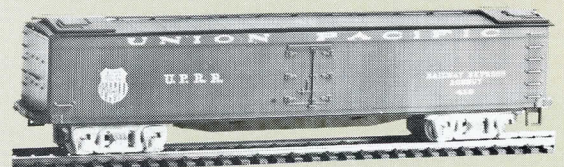

#3602 Union Pacific

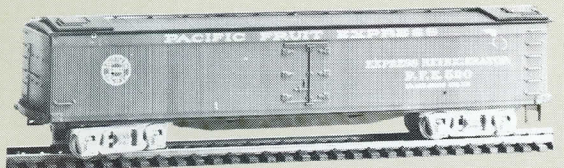

#3603 Southern Pacific P.F.E.

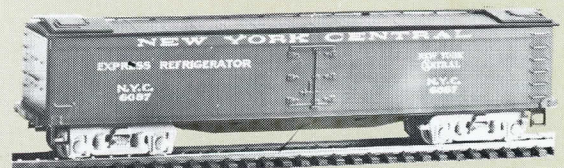

#3604 New York Central

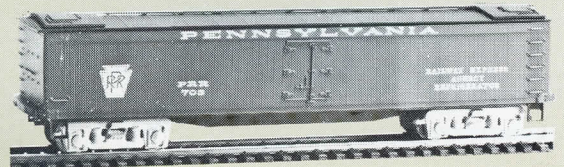

#3605 Pennsylvania

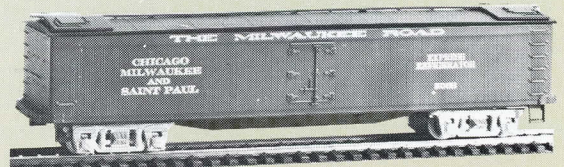

#3606 Chicago, Milw. & St. Paul

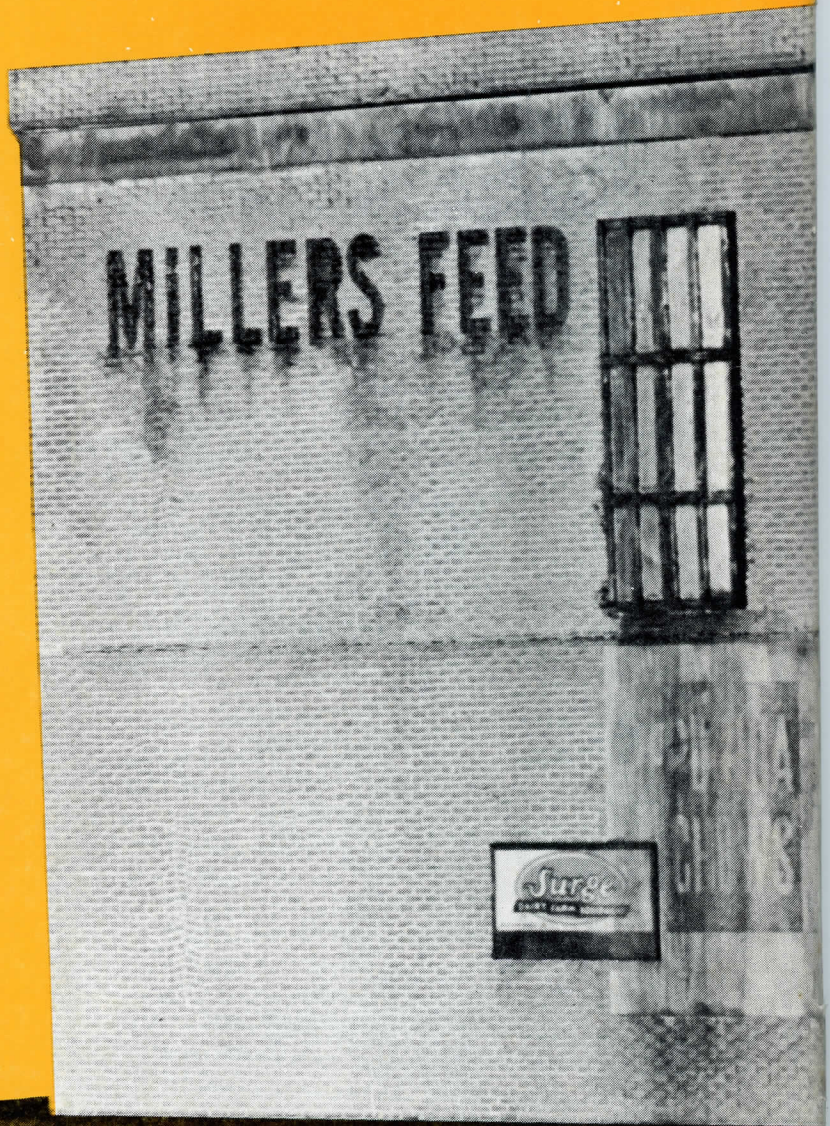

MODEL DIE CASTING, INC.

P.O. BOX 926, HAWTHORNE, CALIFORNIA 90250



H-O SCALE

Build with **Roundhouse Products**

OLD TIMER SERIES **BUILDINGS** "TIME SAVER" KITS



New for '73, Roundhouse Products proudly presents our H-O Scale "Old Timer" building line.

Roundhouse has always strived to bring to the model railroader the finest in H-O scale products and we are introducing a completely new line of H-O scale "Old Timer" buildings to supplement our growing railroad line.

The new Roundhouse building series represents a completely new concept in plastic molded kits. Each kit is built on a "Module", that is, all major components within each style, may be substituted without alternation, to achieve different buildings or unusual effects. Individual buildings may be stacked, one upon the other, or placed in any type of street scene.

Parts are individually colored and the detailed stone and brick walls are preprepared with an authentic weathered appearance.

Also, to add greater flexibility to these new buildings, we are co-introducing a "Module Pack" deal consisting of separate bagged H-O scale parts to facilitate super detailing and add-ons.

- **Injected multi-colored moldings**
- **Modular construction**
- **Ease of assembly**

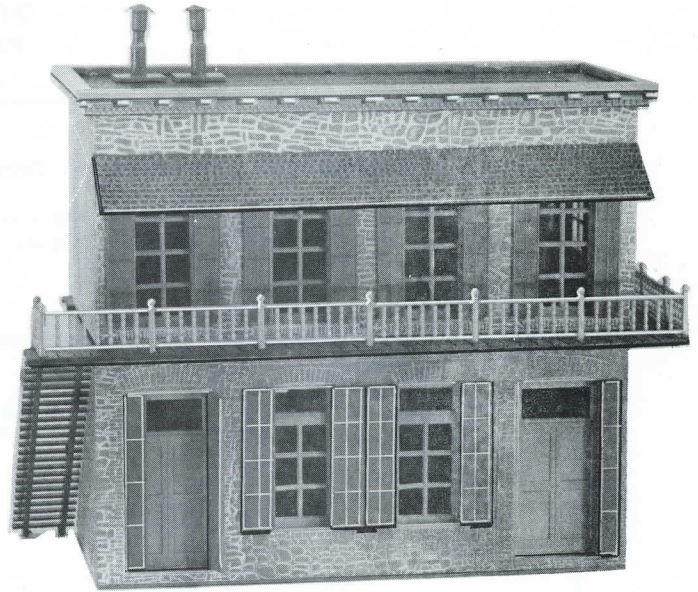

KIT CONTENTS

\$4.98 kit

PARTS

STEEL SHUTTERS

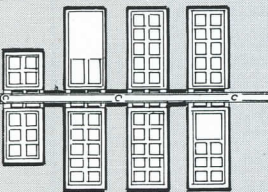
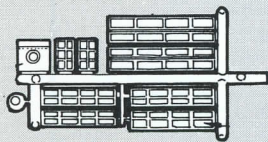

WINDOW MOLDING (upper story)

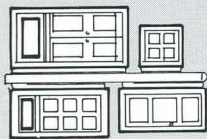

WINDOW MOLDING (lower story)

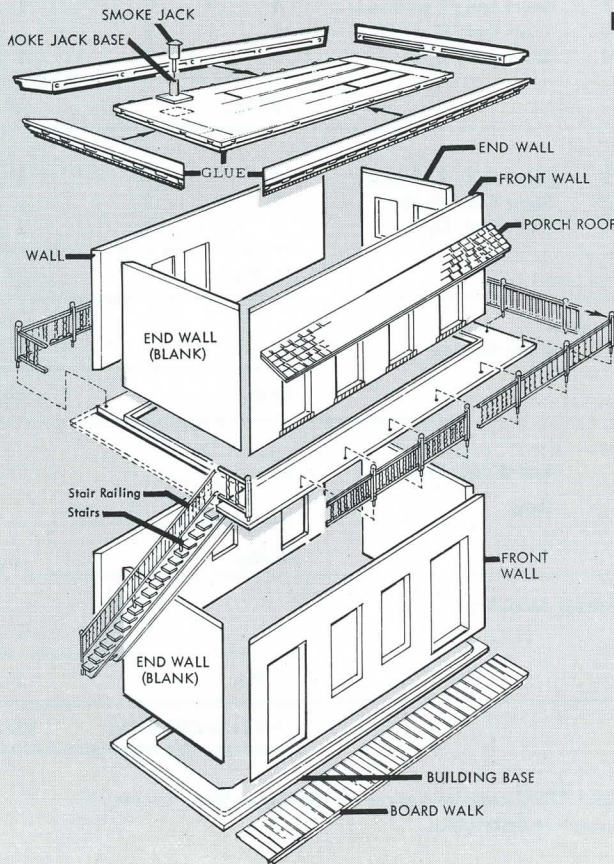

MODULES

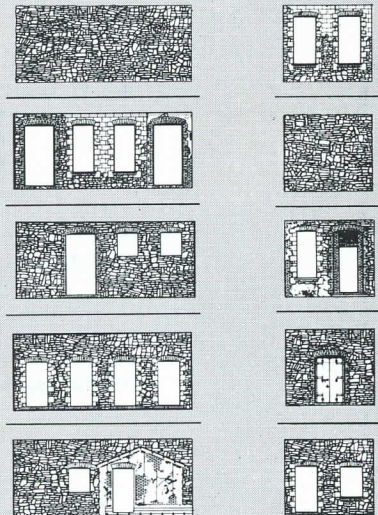

KITS SINGLE STORY

501	Single story brick	2.98
502	Single story stone	2.98

TWO STORY

503	Two story brick	4.98
504	Two story stone	4.98

* 505	Old Town Apartment	* to be announced
* 506	Main Street	

Model Die Casting, Inc.,

3811-15 W ROSECRANS • BOX 926 • HAWTHORNE, CALIF 90250 • (213) 678-3131

MODEL DIE CASTING INC

ROUNDHOUSE PRODUCTS

OLD TIMER SERIES

BUILDING DEAL

#1851

OLD TIMER BUILDING DEAL #1851: Contains eight (8) kits -

		Price Per Kit
4 Kits of #2-01	Two-story brick	@ \$4.98
4 Kits of #2-02	Two-story stone	@ \$4.98
8 kits @ \$4.98		\$39.84

MODULE PACK DEAL: Contains seven (7) divider boxes -

Pack No.	Description	No. of Bags	Contents Per Bag	Price Per Bag
Box 8 Brick Sides:				
2-01-1	Long Side, Front	6	2	\$.75
2-01-2	Long Side, Back	6	2	\$.75
12 Pkg.				\$9.00
Box 9 Stone Sides:				
2-02-1	Long Side, Front	6	2	\$.75
2-02-2	Long Side, Back	6	2	\$.75
12 pkg.				\$9.00
Box 10 Brick Ends:				
0-01-2	Short End, 2 windows	4	2	\$.75
2-01-3	Short End, Blank	4	2	\$.75
2-01-4	Short End, D/W	4	2	\$.75
12 Pkg.				\$9.00
Box 11 Stone Ends:				
0-02-2	Short End, 2 window	4	2	\$.75
0-02-3	Short End, Blank	4	2	\$.75
0-02-4	Short End, D/W	4	2	\$.75
12 Pkg.				\$9.00
Box 12 Doors and Windows				
1852	8 per Casting	12	2	\$.65
12 Pkg.				\$7.80
Box 13 Base Molding:				
1858	Red-6 Bags of each	12	1	\$.50
1859	Gray			
12 Pkg				\$6.00
Box 14 2nd Story Balcony Moulding				
1860		6	1	\$.50
6 Pkg				\$3.00
NET DEALER COST				\$55.58

NOTE Module pack deal #1850 contained seven divider boxes (No. 1 - No. 7)
See deal #1850 for complete description.

ORDER	CAT. NO. NEW OLD	DESCRIPTION	UNIT PRICE	ORDER	CAT. NO. NEW OLD	DESCRIPTION	UNIT PRICE	ORDER	CAT. NO. NEW OLD	DESCRIPTION	UNIT PRICE		
BOX CARS 4# per dozen				TANK CARS 3-1/2# per dozen				50' EXPRESS REEFER					
	3060	B-36	Unlettered	3.00		3360	T-26	Unlettered	3.75		3600	Unlettered	3.75
	3061	B-361	So. Pacific	3.00		3361	T261	Pennsylvania	3.75		3601	Northern Pacific	3.75
	3062	B-362	Santa Fe	3.00		3362	T-262	Santa Fe	3.75		3602	Union Pacific	3.75
	3063	B-363	Col. Midlands	3.00		3363	T-263	Southern Pacific	3.75		3603	Southern Pacific P.F.E.	3.75
	3064	B-364	Ton. & Tidewater	3.00		3364	T-264	Sun Oil	3.75		3604	New York Central	3.75
	3065	B-365	Pennsylvania	3.00		3365	T-265	Union Pacific	3.75		3605	Pennsylvania	3.75
	3066	B-366	No. Pacific	3.00		3366	T-266	Union Tank Line	3.75		3606	Chi. Milw. & St. Paul	3.75
	3067	B-367	Balt. & Ohio	3.00							3608	Central Vermont	3.75
	3068	B-368	N.Y.C. & Hud River	3.00							3609	Hood's Milk	3.75
											3610	Railway Express Agency	3.75
											3611	Borden's Milk	3.75
											3612	Chateau Martin Wine	3.75
BILL BOARD REEFERS 4# per dozen				CABOOSE SMALL SIDE DOOR STYLE									
	3121		Schwarschild & Sulzb.	3.50		3400	3500	Unlettered	3.75				
	3122		Cliquot Club	3.50		3401	3501	Union Pacific	3.75				
	3123		Pabst	3.50		3402	3502	Atlantic Coast Line	3.75				
	3124		Miller High Life	3.50		3403	3503	Chi. Burl. & Quincy	3.75				
	3125		Crazy Water Crystals	3.50		3404	3504	Lehigh Valley	3.75				
	3126		Robert's Meats	3.50									
	3127		Schlitz	3.50		CABOOSE Side dr. blnd. end 3-1/2# per doz.							
	3128		Elwood's Root Beer	3.50		3420	C-20	Unlettered	3.75				
	3129		Coor's	3.50		3421	C-201	Santa Fe	3.75				
	3130		Columbia Soups	3.50		3422	C-202	Erie	3.75				
	3131		Blats Old Heidelberg	3.50		3423	C-203	Illinois Central	3.75				
	3132		Oppenheimer Casing	3.50		3424	C-204	NYC & Hudson River	3.75				
	3133		Goetz Country Club	3.50									
	3134		Peerless Beer Company	3.50									
	3135		Bull Frog Beer	3.50		CABOOSE SIDE DOOR, OPEN END STYLE							
	3136		Tivoli Beer	3.50		3430	C-30	Unlettered	3.75				
	3137		Budweiser Beer	3.50		3431	C-301	Baltimore & Ohio	3.75				
	3138		Heinz 57 Varieties	3.50		3432	C-302	Colorado Midland	3.75				
	3139		BDT Potatoes	3.50		3433	C-303	Cotton Belt S.S.W.	3.75				
	3140		Merchant Dispatch	3.50		3434	C-304	Southern Pacific	3.75				
	3141		Swift Premium Ham	3.50									
	3142		Libby's Pickles	3.50									
	3143		Fruit Growers Express	3.50									
	3144		A. Booth & Co.	3.50									
	** 3145			3.50		CABOOSE 3 WINDOW STANDARD STYLE							
	** 3146			3.50		3440	C-40	Unlettered	3.75				
	** 3147			3.50		3441	C-401	Denver & Rio Gr. W	3.75				
	** 3148			3.50		3442	C-402	Northern Pacific	3.75				
	** 3149			3.50		3443	C-403	Pennsylvania	3.75				
	** 3150			3.50		3444	C-404	Wabash	3.75				
						3445	C-405	Southern Pacific	3.75				
						3446	C-406	Reading	3.75				
						3447	C-407	Canadian National	3.75				
						3448	C-408	Great Northern	3.75				
REFRIGERATOR CARS 4# per dozen				CABOOSE OUTSIDE BRACED STYLE									
	3160	R-36	Unlettered	3.00		3460		Unlettered	3.75				
	3161	R-361	Pennsylvania	3.00		3461		M.K.T.	3.75				
	3162	R-362	Pac. Fruit Express	3.00		3462		Rock Island	3.75				
	3163	R-363	Santa Fe	3.00		3463		Western Pacific	3.75				
	3164	R-364	Canadian National	3.00		3464		Norfolk & Western	3.75				
	3165	R-365	C.M. & St. Paul	3.00									
	3166	R-366	Illinois Central	3.00									
	3167	R-367	Erie	3.00									
	3168	R-368	Houston & Tex. Cent.	3.00									
	3169	R-369	Lehigh Valley	3.00									
STOCK CARS 4# per dozen				CABOOSE 4# per doz.				50' PASSENGER CAR					
	3260	S-36	Unlettered	3.00		3470	C-1	Unlettered 2 window	2.75		5001	Unlettered	4.95
	3261	S-361	Rio Grand Western	3.00		3471	C-11	Pennsylvania	2.75		5002	U.P. C.P.	4.95
	3262	S-362	Chicago Northwestern	3.00		3473	C-13	Burlington Northern	2.75		5003	New York Central	4.95
	3263	S-363	Great Northern	3.00		3474	C-14	Penn Central	2.75		5004	Santa Fe	4.95
	3264	S-364	Pennsylvania	3.00		3480	C-2	Unlettered 4 window	2.75		5005	Chi. Burl. & Quincy	4.95
	3265	S-365	A.T. & S.F.	3.00		3481	C-21	Southern Pacific	2.75		5006	Pennsylvania	4.95
	3266	S-366	New York Central	3.00		3483	C-23	Great Northern	2.75		5007	Virginia & Truckee	4.95
	3267	S-367	Clinchfield C C & O	3.00		3484	C-24	Gr. North, Big Sky Bl.	2.75				
	3268	S-368	Colorado Midland	3.00									

**New Release - Date to be announced

MODEL DIE CASTING INC

3811-15 W ROSECRANS • BOX 926 • HAWTHORNE, CALIF 90250 • (213) 678-3131

ORDER	CAT. NO. NEW OLD	DESCRIPTION	UNIT PRICE	ORDER	CAT. NO. NEW OLD	DESCRIPTION	UNIT PRICE	ORDER	CAT. NO. NEW OLD	DESCRIPTION	UNIT PRICE
50' BAGGAGE				PASSENGER CARS 5# per doz. car kits							
	5021	Unlettered	4.95		6081 P-81	Sleeping Car	6.50				
	5022	U.P. C.P.	4.95		6082 P-82	Observation	6.50				
	5023	New York Central	4.95		6083 P-83	Combination	6.50				
	5024	Santa Fe	4.95		6084 P-84	Dining Car	6.50				
	5025	Chi. Burl. & Quincy	4.95								
	5026	Pennsylvania	4.95								
	5027	Virginia & Truckee	4.95								
				O GAUGE							
				JEWELS							
					7100 OX100	Headlight	.35 pr				
CIRCUS CARS				JEWELS							
	5035	Undecorated	4.95		7101 OX101	Red	.35 dz				
	5036	Barnum & Bailey	4.95		7102 OX102	Green	.35 dz				
	5037	Ringling Bros.	4.95		7103 OX103	Amber	.35 dz				
	5038	Buffalo Bill	4.95		7104 OX104	White	.35 dz				
**	5039	Jos Schlitz	4.95								
**	5040	101 Ranch	4.95								
**	5041		4.95								
				MARKER LAMPS							
	5045	Undecorated	4.95		7110 OX900	3 green 1 red	.75 pr				
	5046	Barnum & Bailey	4.95		7111 OX901	3 amber 1 red	.75 pr				
	5047	Ringling Bros.	4.95		7112 OX902	2 green 2 red	.75 pr				
	5048	Buffalo Bill	4.95		7113 OX903	2 amber 2 red	.75 pr				
**	5049	Jos Schlitz	4.95		7114 OX920	2 green 2 white	.75 pr				
**	5050	101 Ranch	4.95								
**	5051		4.95								
				COUPLERS							
					7120 CO200	Automatic Working	1.00 pr				
HARRIMAN OBSERVATION				BUILDINGS...HO							
	6000	Undecorated	4.95	**	9001						
	6001	Southern Pacific	4.95								
	6002	Chicago & N.W.	4.95								
	6003	Pennsylvania	4.95	**	9002						
	6004	Union Pacific	4.95								
				**	9003						
HARRIMAN COACH				**	9004						
	6010	Undecorated	4.95								
	6011	Southern Pacific	4.95								
	6012	Chicago & N.W.	4.95								
	6013	Pennsylvania	4.95								
	6014	Union Pacific	4.95								
HARRIMAN BAGGAGE											
	6020	Undecorated	4.95								
	6021	Southern Pacific	4.95								
	6022	Chicago & N.W.	4.95								
	6023	Pennsylvania	4.95								
	6024	Union Pacific	4.95								