

# Assembly Instructions

## EMD F-7 DUAL ROAD DIESEL

### In O Gauge by All-Nation

Before starting construction of your F-7 unit, examine all castings and remove all flash. Be careful not to file tongues off top of side casting and groove on bottom of roof casting. All detail parts should be added before unit is assembled. A preliminary assembly is recommended to check the fit to the parts, end to sides, sides to roof, etc.

#### DETAILING

To the end (404) fit two grab irons (these are formed from .032 wire), then mount coupler using 2-56 screw. Then install wire forms for uncoupling (see detail drawing and instructions).

Cement fiber diaphragm (508) to striker plate (509). When dry cement assembly to the door frame with striker plate away from end. Permit the floor sill to come through inside of striker plate when diaphragm is compressed.

Fit door window glass into frame from the inside. (do not install till painting is finished).

Now take the sides (304-305). You have a choice of either one or two headlites. If you want only one, file off boss on nose door. If you want to use two, file out the membrane in nose door. NOTE if you want to use a MARS Lite both lites will have to be used, the top one for the MARS and the bottom for the headlite. If you want 45° number boards see drawing and instructions for their installation.

Fit hand rails (formed from wire in kit) in nose and sides. Then mount front coupler using 2-56 screw. Now mount the uncoupling wire forms on the nose as shown on the drawing. (For best results in Operating Automatic Couplers, solder drawbar handle wire form closed after it has been assembled and installed).

Fit all windows at this time. These are fitted from the back of the casting and not from the front as shown on the drawings. (Do not install till painting is finished).

Place horns in place, one facing forward and one back, and cement or swedge on the inside.

Grill can now be cut to fit A unit (it will not have to be cut for B unit). It fits between the front door and the rear of the unit. This should not be mounted until after the unit is painted.

The roof is now drilled if you want to put the train heating stacks on the rear of the unit. Mark off the roof as shown on drawing and drill with a 17/64" drill. Place the stacks in place and glue or swedge in place. Mount exhaust stacks in place. Mount roof lift rings and bend over on the inside. Fit plastic grill in opening in roof. (do not install till painting is finished).

#### ASSEMBLING

Assemble end and one side with 4-40 screws (C-1405). Do not draw up tight. Start the turnbuckles (222) into bosses in side. Set headlite lenses in place, flat side facing outside. Then start turnbuckles in other side. Draw sides together, using 1/4" open end wrench being careful not to deform the castings. The tongues and grooves must line up. If sides are bent out of shape, loosen and bend back into shape.

Now fasten other side to end with 4-40 screws.

Fasten roof to sides and ends with 4-40 screws. Again be careful that tongues and grooves line up.

Body can now be painted to suit. When paint is dry, mount windows and roof grill using a clear cement. Mount the long metal grill with Goo. If instructions are followed grills will not come loose. If you wish you may want to drill and pin grills in place.

Lite assembly can now be placed in lite compartment and held in place with spring wire ring.

B unit is assembled the same as the A, but use two ends. The roof is attached in the same manner as the A.

# Assembly Instructions

## EMD F-7 DUAL ROAD DIESEL

### In O Gauge by All-Nation

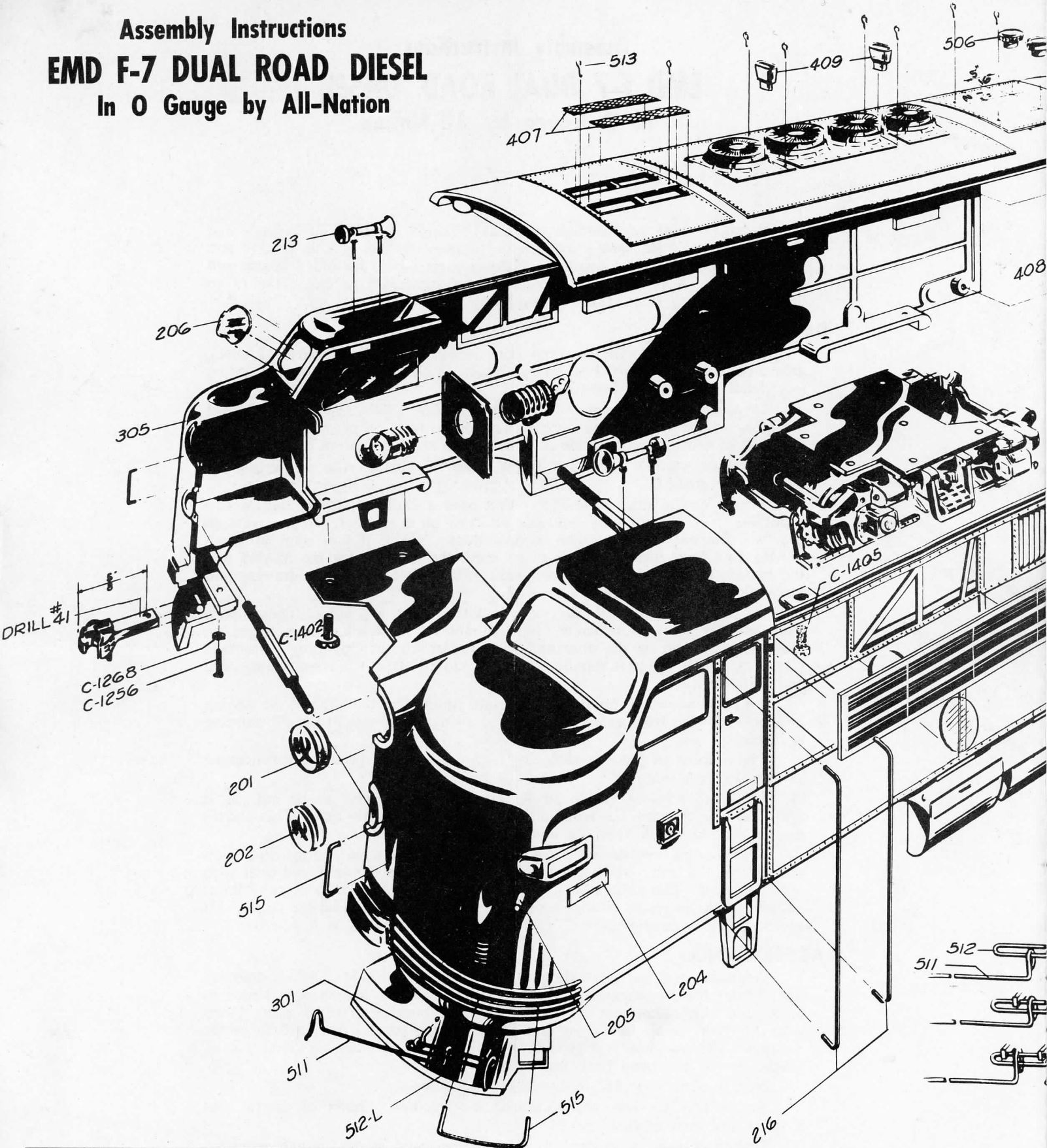

**THE "ALL-NATION LINE"—LEADER IN THE GREATEST VARIETY OF O GAUGE**

Steam Locomotives and Tenders, Diesels, Box Cars, Refrigerator Cars, Flat Cars, Composite Reefers, Watermelon Car, 40 and 50 foot Automobile Cars, Caboose, 40 Ft. Outside Braced Box Cars, Trucks, Ties, Bridges, Mars Lite, Foliage Kits, Brass and Steel Rail, Super Cement and Railroad Lacquers, thousands of parts and accessories.

**ALL-NATION HOBBY**  
 Specialists in Model Railroads — Scale & Tinplate  
 182 No. LaSalle Street • DE. 2-0850 • Ch

LOCATION OF 45° NUMBER  
BOARDS ON THE  
EMD F-7 DUAL ROAD DIESEL

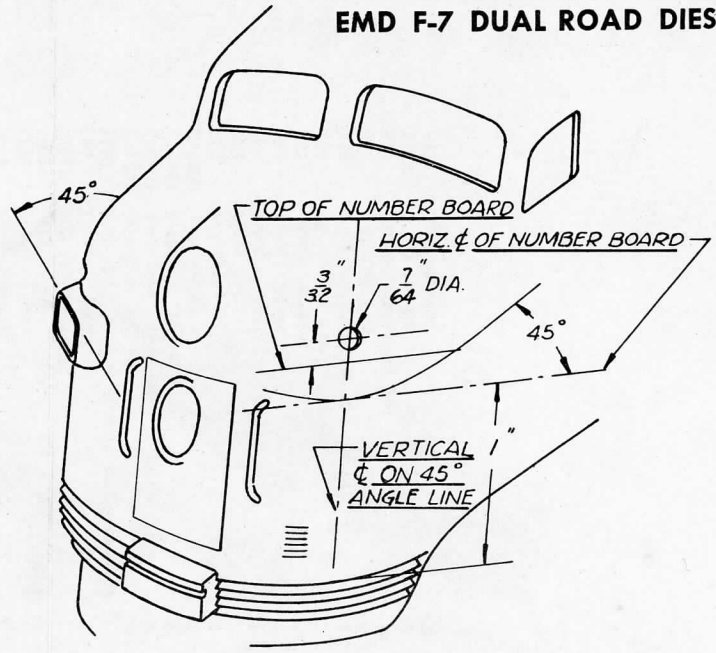
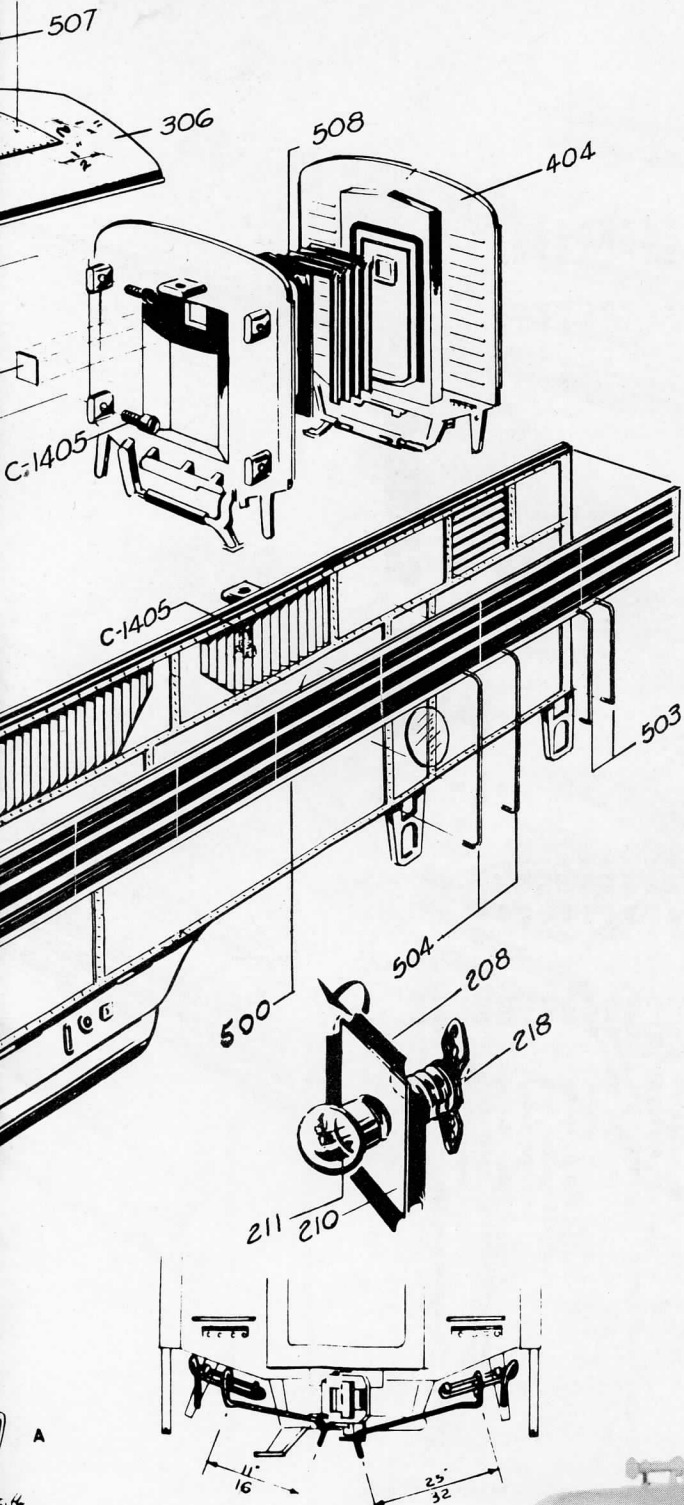

The location and installation of the 45° number boards is as follows:—First, file the flat or side type number board completely off with a wide, fairly fine file. This is done on both sides. Use a 45° angle to find the tangent point anywhere along the nose on the cylindrical section as in Sketch No. 1. By scraping the 45° angle protractor or template up and down the nose, it will leave a line along the 45° tangent point.

Along this centerline measure 1" up from the top anti-climber rails. This will be the horizontal centerline of the number board. Repeat process on the other side.

The simplest method of mounting these lights was found to be cementing them into place with household cement after removing the cast bosses on the inside of the number board casting. The rear indicator or jewel above the number board is located 3/32" above the top of the board. The hole itself should be about a scale 5" diameter, which would be about 7/64".

To illuminate the number board itself, merely open up the nose after fitting the board and scribe the location of the opening on the nose. Fit the acetate "glass" carefully, then paint the inside black and use white number decals on the outside. Scratch the paint from behind the numbers so the light will illuminate them.

**SHOP**  
Chicago 1, Illinois



EMD F-7 DUAL ROAD DIESEL

# PARTS LIST

	A	B	Price
	unit	unit	
101A	4	4	1.20 ea.
404	1	2	2.50 ea.
1004	1	2	.50 ea.
304-7	1	1	9.50 ea.
305-7	1	1	7.50 ea.
306-7	1	1	7.50 ea.
901-7	1	1	8.50 ea.
902-7	1	1	8.50 ea.
903-7	1	1	8.50 ea.
400	1	1	.65 ea.
508	1	1	.40 Pr.
509	1	2	.20 pr.
1008	2	2	.06 ft.
1908	1	2	.25 ea.
1903	1	2	.03 ft.
1903A	1	2	.03 ft.
500	2	2	1.00 pr.
2480	1	2	
C-1256	2	2	.25 dz.
C-1402	8	8	.25 dz.
C-1407	9	9	.25 dz.
C-1800	2	2	.15 dz.
213	2	2	.25 ea.
222	2	2	.50 pr.
409	2	2	.15 ea.
506	2	2	.15 ea.
507	1	1	.15 ea.
204	1	1	.50 pr.
2481	2	2	
301	4	4	.03 ea.
511	4	4	.03 ea.
512R	2	2	.03 ea.
512L	2	2	.03 ea.

	A	B	Price
	unit	unit	
513	10	1	4/.10
2482	1	1	.15 ea.
201	1	1	.15 ea.
202	1	1	.10 pr.
205	2	2	.05 ea.
209	1	1	.15 ea.
210	1	1	.05 ea.
220	1	1	.20 ea.
4016	1	1	.25 ea.
4018	1	1	.25 ea.
2483	1	1	.25 dz.
C-1256	2	2	.25 dz.
C-1402	8	8	.25 dz.
C-1407	14	14	.25 dz.
C-1800	2	2	.15 dz.
409	2	2	.15 ea.
506	1	1	.15 ea.
507	1	1	.15 ea.
2484	1	1	.03 ea.
511	4	4	.03 ea.
512R	2	2	.03 ea.
512L	2	2	.03 ea.
513	14	14	4/.10
2485	1	1	.15 dz.
C-1804	2	2	.15 ea.
C-2032	4	4	.05 ea.
C-2036	2	2	.05 ea.
103	4	4	.10 ea.
109	8	8	.15 pr.
1009	2	2	.15 ea.
1013	8	8	.15 ea.
3818	2	2	.98 pr.

**All-Nation Hobby Shop**  
 182 North La Salle — Chicago 1, Illinois