

# ASSEMBLY INSTRUCTIONS

## ALL-NATION FISHBELLY FLAT CAR

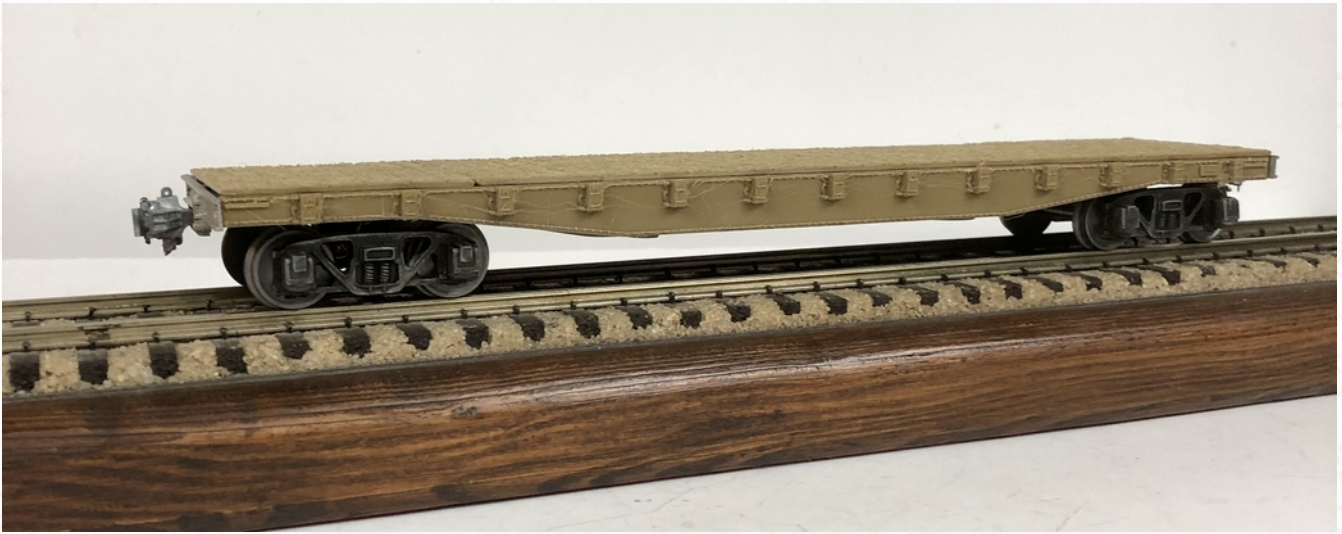

Before starting to build this car read these instructions and study the assembly drawings. Although this car is quite simple to build there are certain precautions that should be followed.

- 1 - Carefully clean all flash from the main casting with a file and sharpen up any of the detail that may need touching up. THIS IS THE MOST IMPORTANT PART OF THE PROCEDURE.
- 2 - Drill one hole in the end of the car deck as shown using a #65 drill for mounting the brake wheel. The brake wheel and rod will be installed later.
- 3 - The couplers should next be mounted. This is accomplished by first assembling the coupler and coupler mounting plate as shown in the drawing. The #0 x 3/16" drive screw should be inserted into the middle hole of the coupler mounting plate #2126 and then driven into the middle hole in the coupler. BE SURE coupler is positioned correctly before making this assembly. The assembly may then be fastened to the underside of the car by using the #00 x 3/16" drive screws, driving them into the holes provided.
- 4 - Bend car steps as shown and spot two holes at each of the four corners for mounting the car steps. These holes should be drilled with a #70 drill. The steps may be mounted in place by using the #22 escutcheon pins as rivets and driving them into the holes which have been drilled. A nail set will be found very useful in performing this operation.
- 5 - The trucks may now be assembled for mounting on the car. When fastening the trucks to the chassis it is desirable to use a little light oil on the threads of the truck pivot screws before inserting them into the threaded holes provided.
- 6 - The brake rod is made using the .032 brass wire. The brake wheel is pressed on the brake rod and soldered. It may now be installed in the mounting hole which had previously been drilled.
- 7 - Mount A-B brake set as shown on drawing.
- 8 - The car is now ready for painting. Before doing so be sure that the metal is perfectly clean. Wiping the parts off good with lacquer thinner will assure a clean surface on which to apply your paint. This car may be all black or tuscan red depending on the prototype being followed. White decals may be applied after painting as desired.

Your All-Nation Fishbelly Flat car is now complete and we know you are well pleased with the results.

# Assembly Instructions

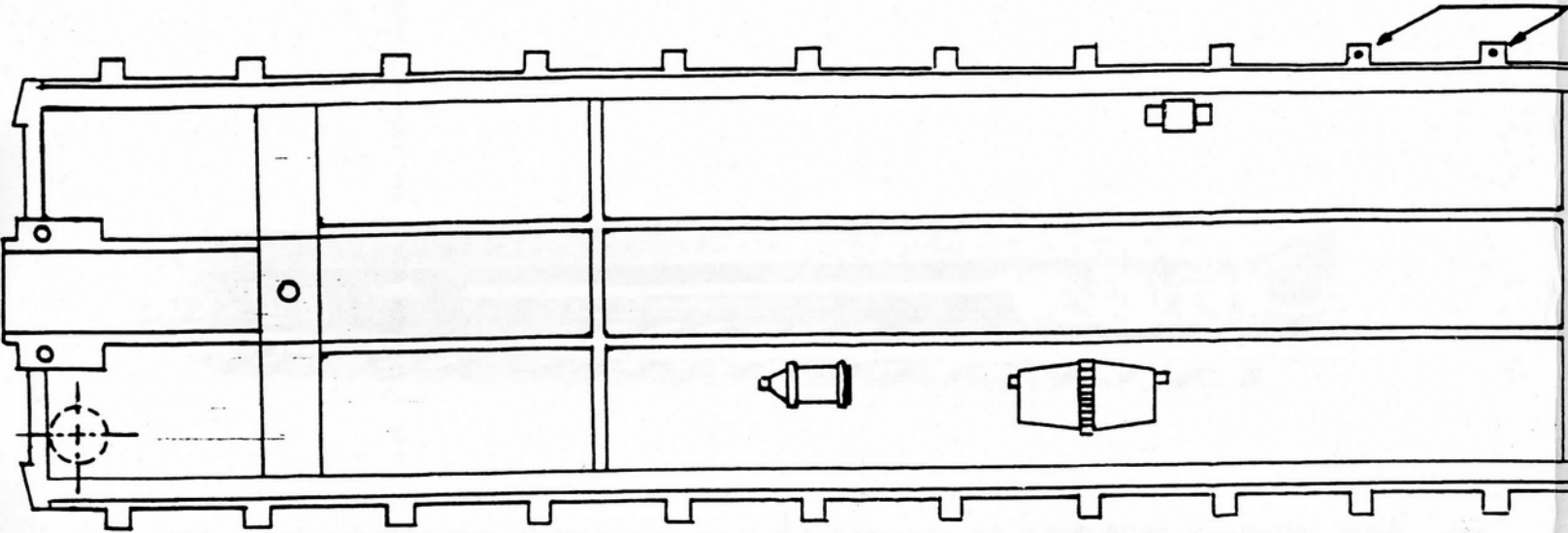

Drill #65 Hole  
For Brake Rods

## FISHBELLY FLAT CAR IN O GAUGE - BY ALL-NATION SCALE or TINPLATE

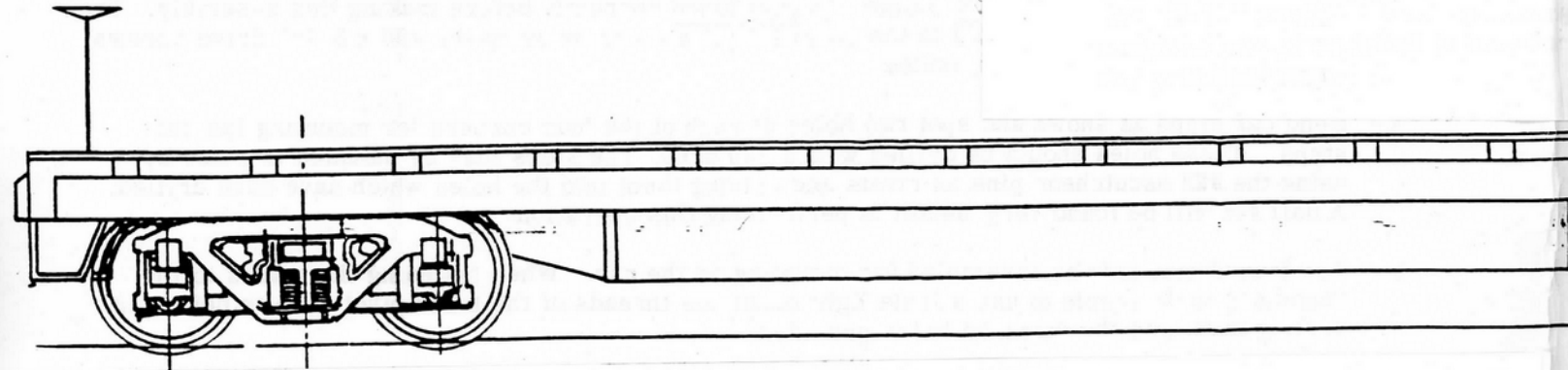

DRILL #60  
30 Holes

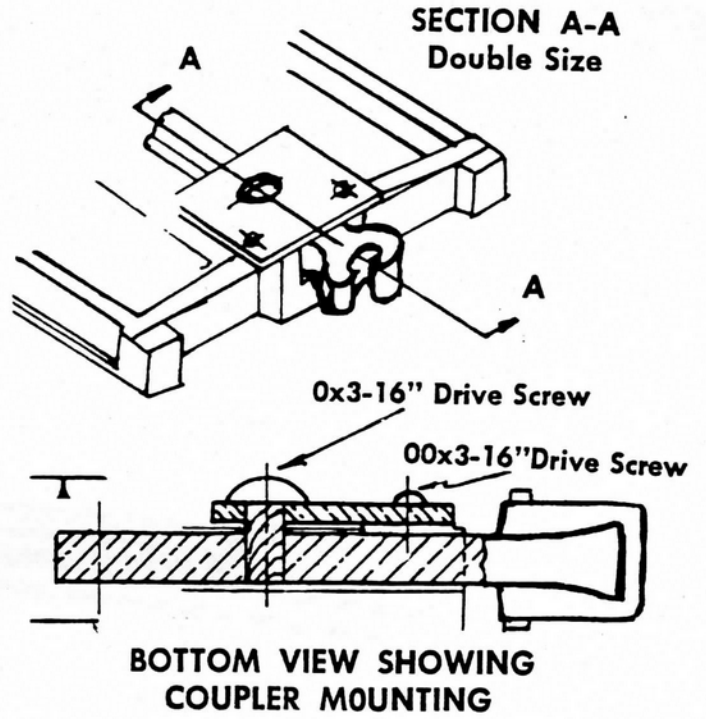
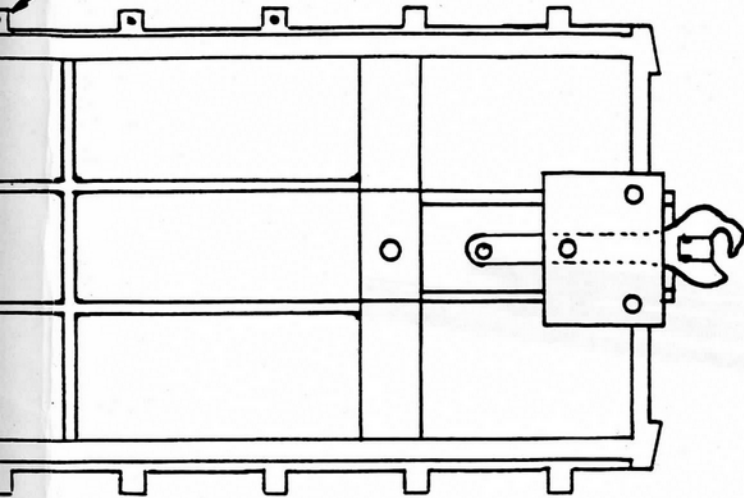

STEP DETAIL DOUBLE SIZE

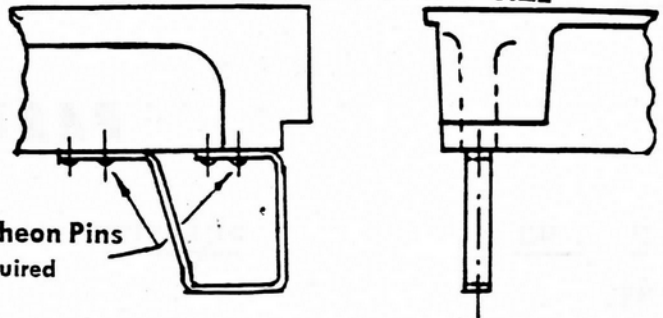

#22 Brass Escutcheon Pins  
Only Two Required

SPOT DRILL #30-FILE AROUND  
To Give Proper Effect

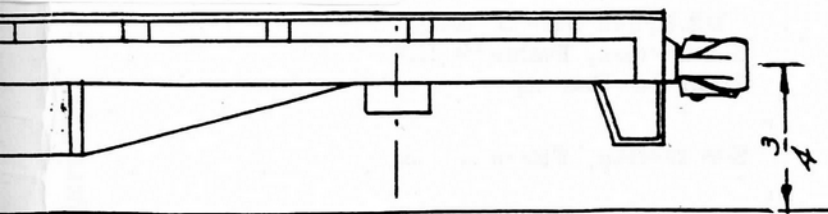
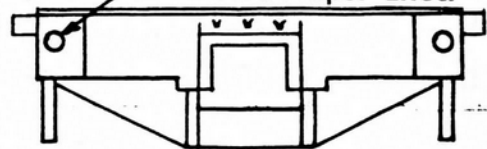

R. J. BOSAK

The "ALL-NATION LINE" Greatest Variety in O Gauge

**SPRUNG DRAFT GEAR**  
Another Specialty by All-Nation



Easily  
Adaptable  
To All  
Cars  
Pair  
50c

For Realistic Starts and Stops

THE **ALL-NATION LINE**

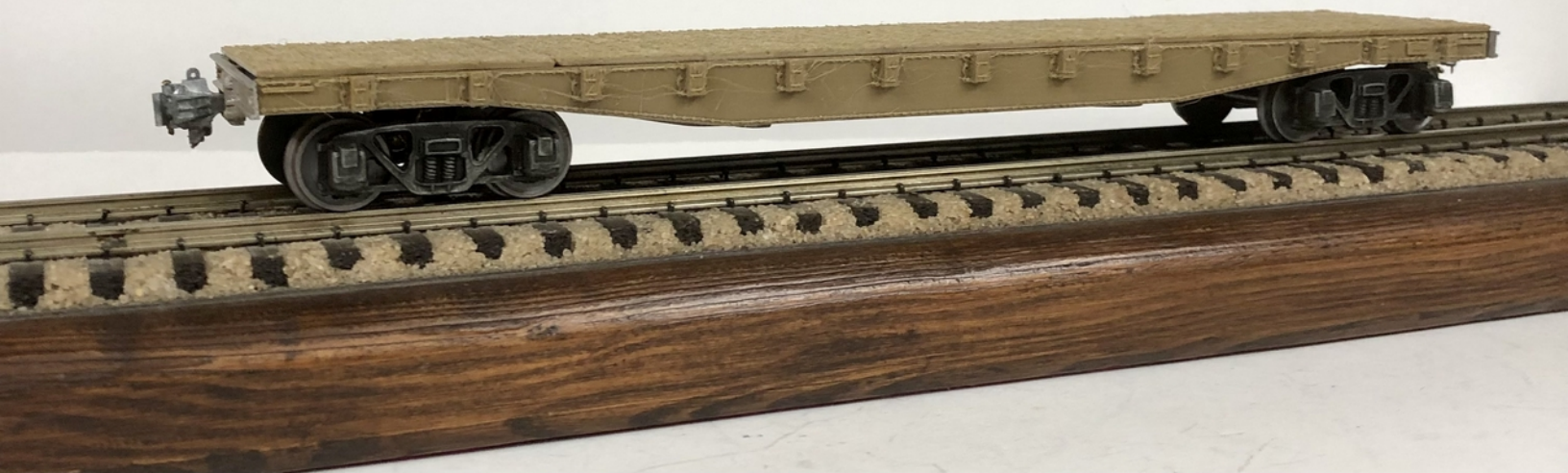

## PARTS LIST

<u>PART NO.</u>	<u>QUANTITY</u>	<u>DESCRIPTION</u>
3614	1	Fishbelly Flat Car Kit (Less Truck & Couplers)
1903-C	1	.032 Brass Wire 5" long
2420	1	Sub section, Fishbelly flat
3614-C	1	Main Car Casting
2420	1	Sub section, Fishbelly flat
1698-B	1	AB brake set
C-1901	4	#00 x 3/16" Drive Screw
C-1902	2	#0 x 3/16" Drive Screw
C-2018	8	#22 Brass Escutcheon Pins
2126	2	Coupler Mounting Plates
3125	1	Brake Wheel
3022	4	Car Steps

# ALL-NATION HOBBY SHOP

EVERYTHING FOR THE BUILDER AND COLLECTOR

182 North La Salle Street

Chicago 1, Illinois