

3340T COMBINE

"O" GAUGE

WM. K. WALTHERS INC.

PLAN VIEWS FOR "O" GAUGE MODEL SCALE: 1/8" size.

60-1113

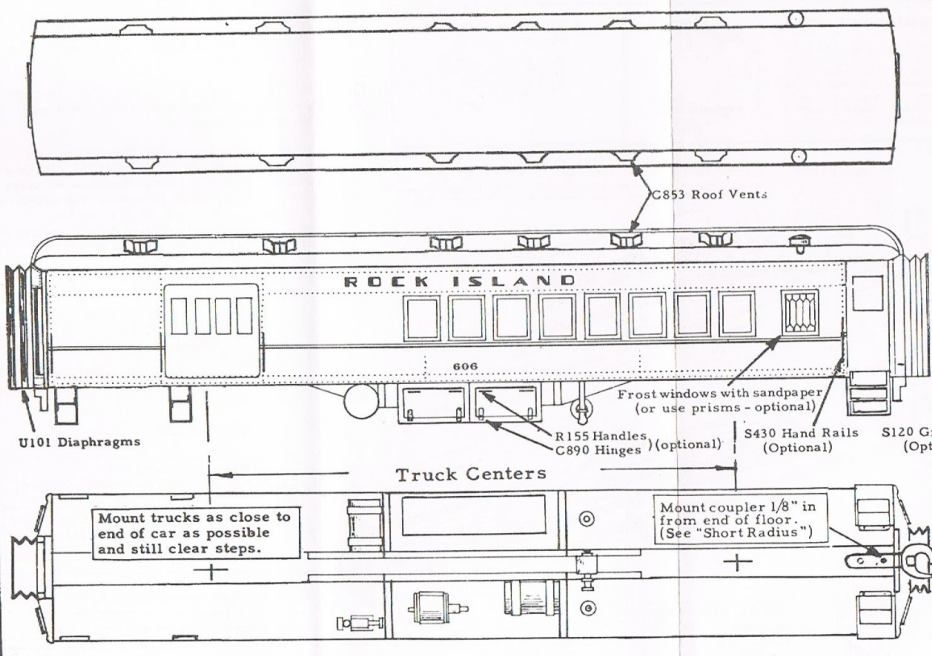
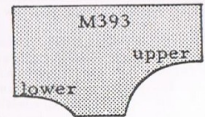

FULL SIZED TEMPLATE FOR ROOF

Trace or cut out (after reading other side) and use to check rounding of roof deck.

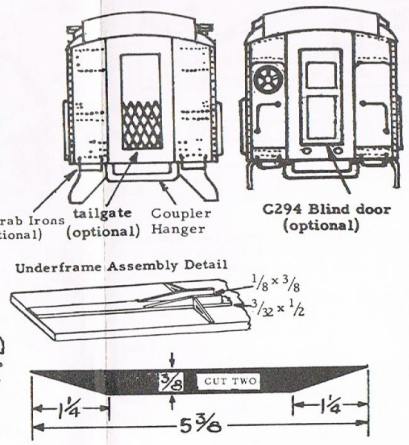

HEY, HERE'S SOMETHING NEW!

One of the really new features of this kit is the method of cementing the sides to the body. BUT, you need a cement that will hold wood to metal: one that will NOT come loose in a damp basement, a cement that will NOT crack even if the model is stored in an attic where the temperature may change rapidly from sub-zero to plus 120°. **GOO WILL DO THIS JOB.**



We have tested Goo continuously since 1949 and we KNOW it will do this job (and most any other cementing job). Don't take a chance with an ordinary cement. Your models deserve Goo. Try it. Give Goo a chance to show you some new tricks.

FOLLOW DIRECTIONS. It is important and to your advantage to coat both surfaces with Goo and let dry for 2-3 minutes as it says on the tube. Or, if you prefer, you may use the **TRANSFER METHOD.** Coat one part with Goo, press into place and remove. Goo has now "transferred" to the other surface. WAIT 2-3 minutes while the excess solvent evaporates and tack builds up, then press into place for final assembly. You'll be amazed at the difference this simple procedure makes in the speed with which your joints set and the ease with which your models Goo together.

SUPER DETAILS To keep basic kit cost low, we packed super detail parts (marked * or "optional") in a separate kit. Included are: hand rails, grab irons, prism windows, guard chain, tailgates, box cover detail, roof bead castings. Also available are accessories such as interiors, lights, markers, air conditioners to make your car a real show piece. Consult catalog.

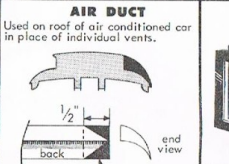

Cut off shaded area (both ends) CAREFUL not to break feather edge. Shape front or top surface, sand smooth. Fit to roof (remove roof beading). See end illustration for finished view.

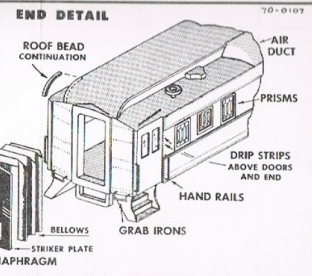

ROOF ROUNING
Shape lower monitor (L) Make curved bead from stripwood (or use *C979 cast bead). Fit to roof. Shape upper monitor (U) to match bead.

REMOVABLE ROOF
A removable roof is desirable when interiors or lighting are planned. *U750 removable roof kit makes this easy, provides electrical connection to trucks. *R276 metal angles (cemented or soldered) will reinforce sides.

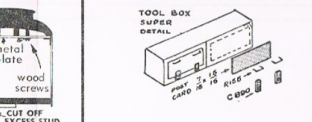

E Complete the underbody details with both standard and optional superdetail parts, sealing any needed dimensions from the plan. See "F" for mounting strap steps.

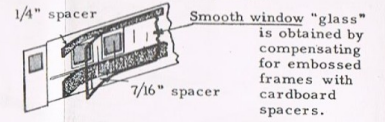

F Prepare the sides, mounting all desired details and fastening side doors in place. (Doors can be made to slide using R157 door slides.) Doors must be trimmed to fit in space provided. Check the sides against the body for fit and CUT AWAY roof and floor for clearance as required. Now mount strap steps in floor as shown. (Alt. method: solder steps to car side). Paint the sides, then install window material.

G Prepare roof, installing details with Goo as shown on the plans and rounding the ends with file and sandpaper to contour shown in the drawings.

H Paint the body, except do not paint the edges of the floor and roof where the sides will be cemented in place.

I Fasten sides to body with Goo as follows: Coat the edge of the floor and roof with Goo and press the sides in place. Remove the sides and allow the Goo, which is now on the sides as well as the floor and roof, to dry for two minutes. Then press the sides firmly in place. The joint will set very quickly this way.

J Mount trucks and couplers.

Sides, floor, and roof are all cut to exact size. You do not have to trim them. Roof is 1/2" longer than sides and floor.

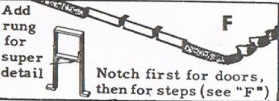

"Goo" is the registered trade mark of Walther's Specialties, Inc. for their unique all-purpose permanent rubber base adhesive.

ASSEMBLY OUTLINE

- A** Clean flash from end castings. Fasten optional super detail parts to ends if desired. (See note on "Super Details".)
- B** Fasten ends to floor and roof with screws and Goo (inset "B"). Follow directions on Goo tube for quickest bond.
- C** Notch floor to provide clearance for vestibule door and step (see inset "C").
- D** Locate truck centers for the trucks you will use. Cut centersill parts from wood and assemble on floor, reinforcing fishbelly sections with pins. Be sure the centersill is centered on the floor.

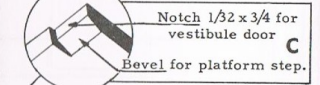
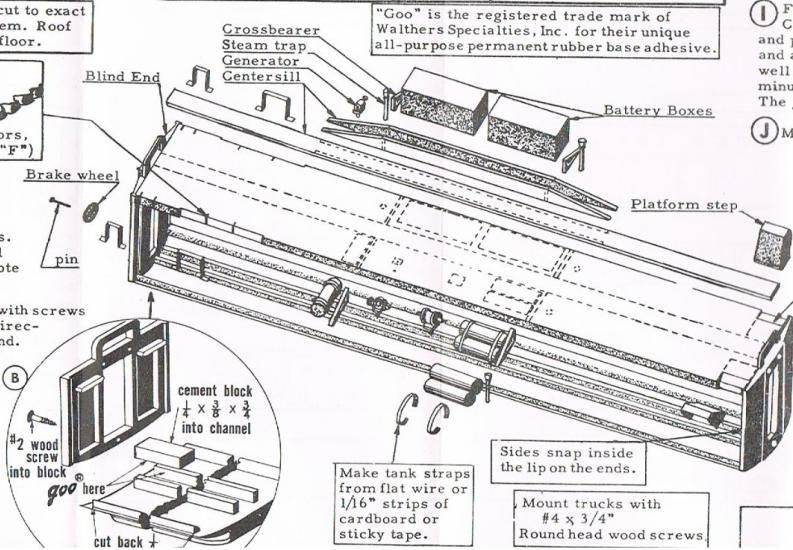

Mount couplers with #2 x 3/8 round head wood screws

Fasten ends to roof and floor with #2 x 1/2" Flat Head Wood Screws. (See inset "B")

IMPORTANT: These General Instructions show the body assembly of any car of this type. Car plans on the reverse will show where to locate all detail parts.

Make tank straps from flat wire or 1/16" strips of cardboard or sticky tape.

Sides snap inside the lip on the ends.
Mount trucks with #4 x 3/4" Round head wood screws.