

3305 T PULLMAN

"O" GAUGE

PLAN VIEWS FOR
O GAUGE MODEL
SCALE: 1/8" O ga size.
60-0929-1

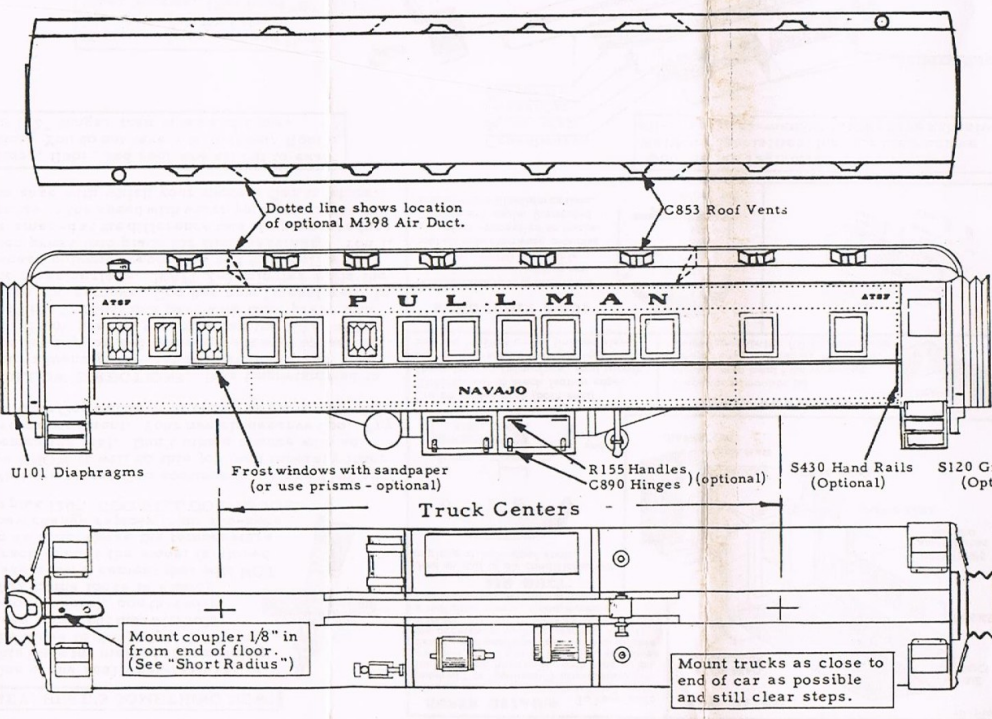

ALL NATION LINE
23 W 546 ST. CHARLES RD.
WHEATON, IL 60188

M393
upper
lower

FULL SIZED TEMPLATE FOR ROOF

Trace or cut out (after reading other side) and use to check rounding of roof deck.

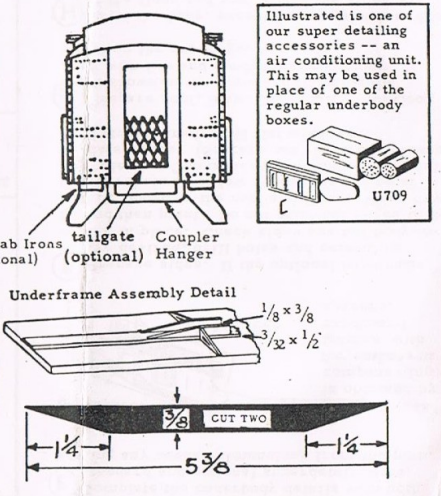

HEY, HERE'S SOMETHING NEW!

One of the really new features of this kit is the method of cementing the sides to the body. BUT, you need a cement that will hold wood to metal: one that will NOT come loose in a damp basement, a cement that will NOT crack even if the model is stored in an attic where the temperature may change rapidly from sub-zero to plus 120°. **GOO WILL DO THIS JOB.**



We have tested Goo continuously since 1949 and we KNOW it will do this job (and most any other cementing job). Don't take a chance with an ordinary cement. Your models deserve Goo. Try it. Give Goo a chance to show you some new tricks

FOLLOW DIRECTIONS. It is important and to your advantage to coat both surfaces with Goo and let dry for 2-3 minutes as it says on the tube. Or, if you prefer, you may use the **TRANSFER METHOD.** Coat one part with Goo, press into place and remove. Goo has now "transferred" to the other surface. WAIT 2-3 minutes while the excess solvent evaporates and tack builds up, then press into place for final assembly. You'll be amazed at the difference this simple procedure makes in the speed with which your joints set and the ease with which your models Goo together.

Sides, floor, and roof are all cut to exact size. You do not have to trim them. Roof is 1/2" longer than sides and floor.

Fasten ends to roof and floor with #2 x 1/2" Flat Head Wood Screws. (See inset "B")

ASSEMBLY OUTLINE

- A** Clean flash from end castings. Fasten optional super detail parts to ends if desired. (See note on "Super Details".)
- B** Fasten ends to floor and roof with screws and Goo (inset "B"). Follow directions on Goo tube for quickest bond.
- C** Notch floor to provide clearance for vestibule door and step (see inset "C").
- D** Locate truck centers for the trucks you will use and Goo the diecast body bolsters in place. Cut centersill parts from wood and assemble on floor, reinforcing the fishbelly

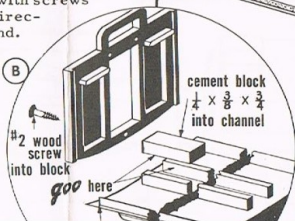

SUPER DETAILS

In order to keep the price of the basic kit as low as possible, we have packed the super detailing parts (usually referred to as "optional" on the plans) in a separate kit. These kits, which include hand rails, grab irons, prism windows, guard chain for the trucks, hinges and handles for underbody boxes are available for all styles of cars. You may also purchase accessories such as air conditioning strips, marker lights, venetian blind decals, interior detailing, and lighting kits that will make your car a real show-piece. Consult catalog for listings.

REMOVABLE ROOF

A removable roof is desirable if interior detailing or lighting is planned. To provide for it, cut away the regular side support rails and make a new support frame as shown. Sides will be Gooed to this new frame.

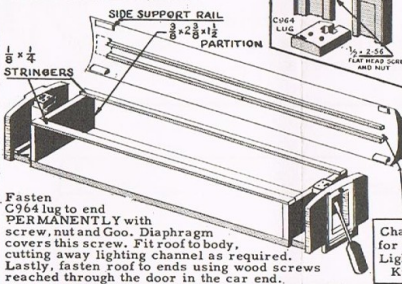

Fasten lug to end first. Run screw through end, start nut, then slip lug over nut & tighten.

Fasten C964 lug to end PERMANENTLY with screw, nut and Goo. Diaphragm covers this screw. Fit roof to body, cutting away lighting channel as required. Lastly, fasten roof to ends using wood screws reached through the door in the car end.

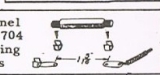
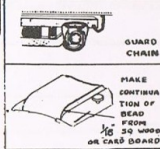
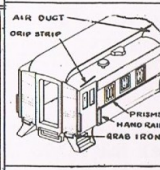

E Complete the underbody details with both standard and optional superdetail parts, scaling any needed dimensions from the plan.

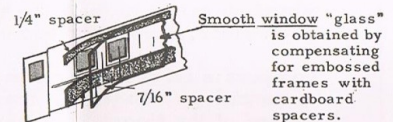

F Prepare sides. If the optional hand rails are desired, drill holes and cement or solder in place. Check sides against body for fit and then paint. Do not paint the edges that will be Gooed to the roof and floor. When dry, Goo cardboard window spacers to inside of car side, then Goo transparent window material to the spacers. (Spacers not required on cars with streamlined-style flat windows.)

G Prepare roof, installing details with Goo as shown on the plans and rounding the ends with file and sandpaper to contour shown in the drawings.

H Paint the body, except do not paint the edges of the floor and roof where the sides will be cemented in place.

I Fasten sides to body with Goo as follows: Coat the edge of the floor and roof with Goo and press the sides in place. Remove the sides and allow the Goo, which is now on the sides as well as the floor and roof, to dry for two minutes. Then press the sides firmly in place. The joint will set very quickly this way.

J Mount trucks and couplers.



Vestibule End

Mount couplers with #2 x 3/8 round head wood screws

Three #2 x 1/2 FHWS will be covered by Diaphragm.

IMPORTANT: These General Instructions show the body assembly of any car of this type. Car plans on the reverse will show where to locate all detail parts.

Sides snap inside the lip on the ends.

Mount trucks with #4 x 3/4"

Make tank straps from flat wire or 1/16" strips of cardboard or