

# Simple Locomotive Directional Lighting Circuit (2-Rail DC)

## How the circuit works

In a 2-rail DC system, the rails carry both power and direction — reversing the throttle flips the polarity. The key is wiring both LEDs in opposing polarities (anode-to-cathode, cathode-to-anode) across the motor/track leads. When current flows forward, only the front LED has correct polarity to light; reverse the current and only the rear LED lights. Each 1K ohm resistor limits current to keep the LEDs safe (typically ~9–12mA at O scale voltages of 9–18V).

The resistor and LED pairs are wired in series — resistor first, then LED — from each rail pickup to the opposite rail. This is the whole circuit; no capacitors or diodes needed.

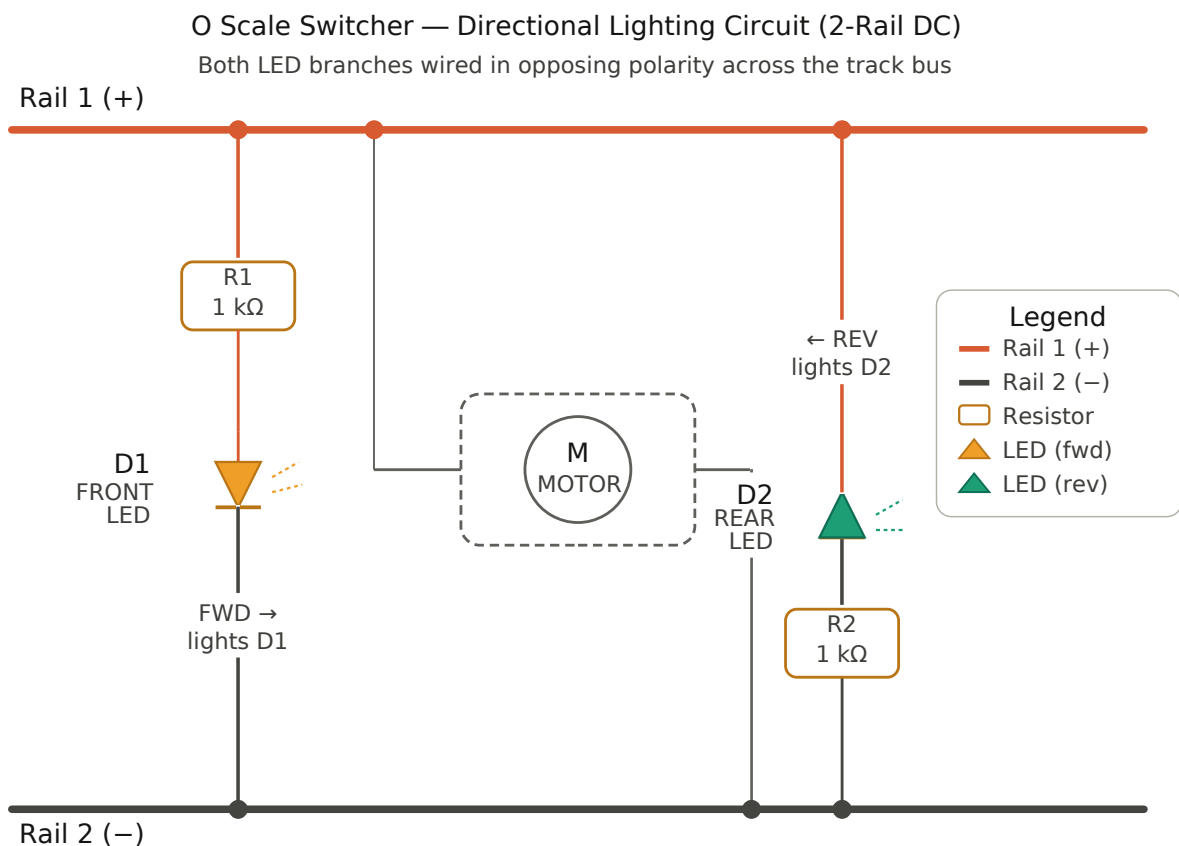

## Wiring it up step by step

For the front LED (D1): run a wire from Rail 1 (+), through R1 (1K ohm), into the anode (+) leg of D1, and out the cathode (-) to Rail 2. When the throttle is set to Forward (Rail 1 = +), current flows through this path and D1 lights.

For the rear LED (D2): run a wire from Rail 2 (-), through R2 (1K ohm), into the cathode (-) leg of D2, and out the anode (+) to Rail 1. This branch is wired in the opposite polarity. When you set Reverse (Rail 1 = -), current flows the other way through D2's path and it lights instead.

The motor connects to both rails in parallel with the LED branches and runs normally in either direction.

### **Practical tips for installation**

For the resistors, 1K ohm is a safe, conservative choice that will give you a moderate brightness at typical O scale voltages (12–18V). If the LEDs seem dim at lower throttle settings, you could go down to 470 ohm, but 1K protects the LEDs well across the full voltage range.

The 5mm LEDs will likely need to be trimmed or mounted in a small housing to fit inside the locomotive body. Warm white LEDs (2700–3000K) look most realistic for headlights on a switcher. Make sure you identify the anode (longer leg) and cathode (shorter leg, flat side on the base) before soldering — the polarity is critical to this circuit working correctly.